

MOULD CYCLE COUNTER

Mould Cycle Counter – Right

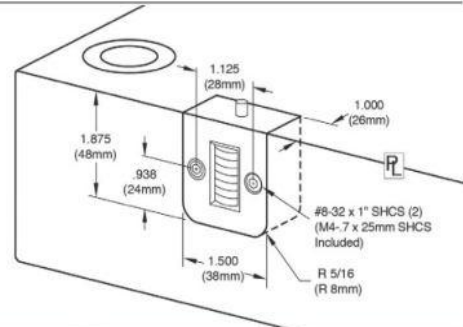

Part No.	Orientation	# digits	Colour	Temp range
CC-200-R-HT	Right (moving half)	7	Black/Red	190°C

Mould Cycle Counter – Left

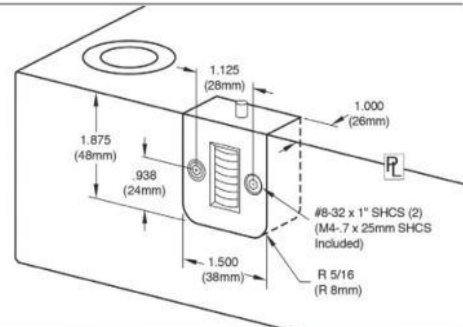

Part No.	Orientation	# digits	Colour	Temp range
CC-200-L-HT	Left (fixed half)	7	Black/Red	190°C

Mouldpro Cycle Counter positively monitors mold activity, validates process monitoring data, and assists mold maintenance procedures.

- Maximum operating temperature is 190°
- Counter: Non-resettable mechanical, 7-digit
- High Temp housing
- Reliable and tested quality
- Specified worldwide by leading OEM's
- Supplied with serial Number
- Socket head cap screws are included