

Pneumatic Ejector Coupling

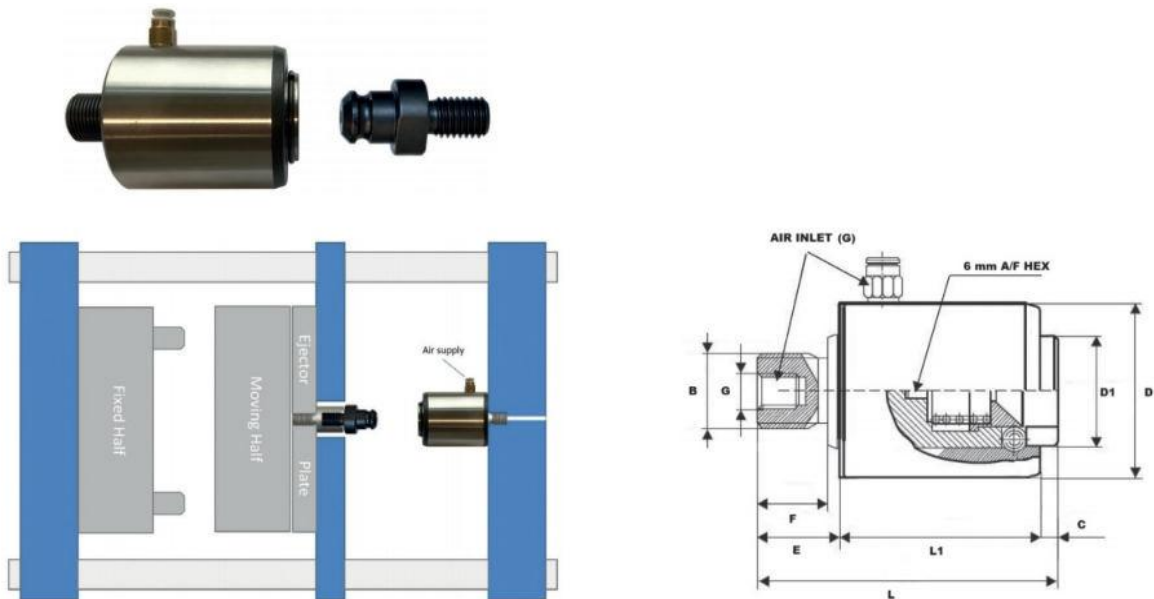

Part No.	D	D1	L	L1	E	F	B	G 4-6 Bar	Pull Force	Size	
EJC-FP-200	48	39	68	28,5	21	15	M16x2	R1/8"	2700 kg	2	1
EJC-FP-205	48	39	68	28,5	21	15	M18x1,5	R1/8"	2700 kg	2	1
EJC-FP-300	58	36	94	66	22,5	20	M20X1,5	R1/8"	3400 kg	3	1
EJC-FP-305	58	36	94	66	22,5	20	M20X2,5	R1/8"	3400 kg	3	1

Ejector Coupling to ensure rapid and safe mould changes designed to fit with standard EJC-M connectors.
 The EJC-FP coupling is air operated. The coupling connects mechanical to the plug EJC-M, and disconnected using air in one of the 2 ports.
 The Unit EJC-FP is installed on the machine and the plug EJC-M is installed on the mould/rod.

Ejector Nipple



Part No.	A	C	D	E	Pull Force	Size	
EJC-M-1-1	M10X1,5	22,8	20	45,5	1500 kg	1	1
EJC-M-1-2	M12X1,75	22,8	20	45,5	1500 kg	1	1
EJC-M-1-3	M14X2	22,8	20	45,5	1500 kg	1	1
EJC-M-1-4	M16X2	22,8	20	45,5	1500 kg	1	1
EJC-M-2-1	M10X1,5	25,8	20	55	2400 kg	2	1
EJC-M-2-2	M12X1,75	25,8	20	55	2400 kg	2	1
EJC-M-2-3	M14X2	25,8	20	55	2400 kg	2	1
EJC-M-2-4	M16X2	25,8	20	55	2400 kg	2	1
EJC-M-3-1	M16X2	35	25	68	3200 kg	3	1
EJC-M-3-2	M18X2,5	35	25	68	3200 kg	3	1
EJC-M-3-3	M20X2,5	35	25	68	3200 kg	3	1
EJC-M-3-4	M24X3	35	25	68	3200 kg	3	1
EJC-M-3-5	M27X3	35	25	68	3200 kg	3	1
EJC-M-3-6	M30X3,5	35	25	68	3200 kg	3	1

Material: 1.7147 - 60 HRC.