

CCAQ. – Compact Cylinder

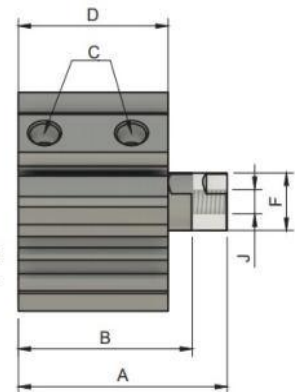
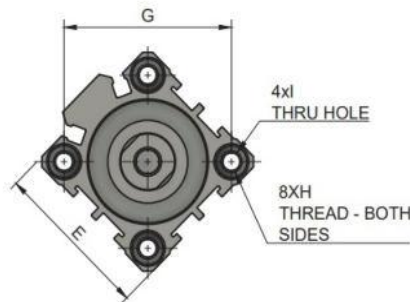
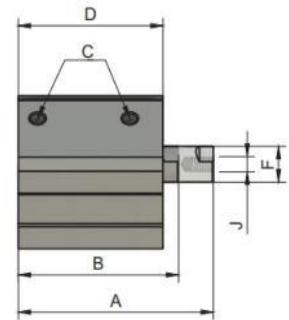
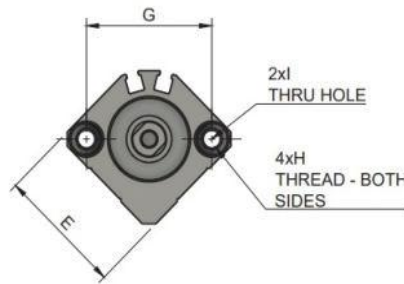
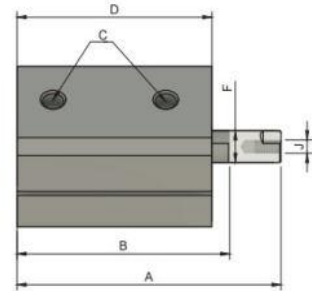
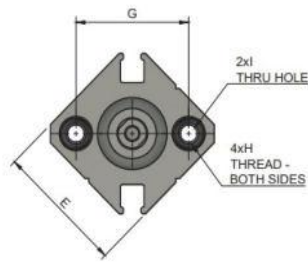
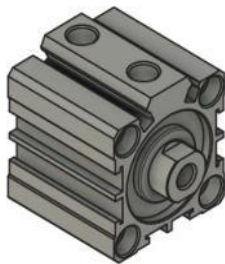

Part No.	Piston bore	Stroke	A	B	C	D	E	F	G	H	I	J	Weight (g)
CCAQ.1210	12	10	51,5	41,5	M5X0.8	38	25	6	22	M4X0.7	Ø3.4	M3X0.5	44
CCAQ.1220	12	20	71,5	51,5	M5X0.8	48	25	6	22	M4X0.7	Ø3.4	M3X0.5	69
CCAQ.1230	12	30	91,5	61,5	M5X0.8	58	25	6	22	M4X0.7	Ø3.4	M3X0.5	81
CCAQ.2010	20	10	56	46	M5X0.8	41,5	36	10	36	M6X1.0	Ø5.2	M5X0.8	106
CCAQ.2020	20	20	76	56	M5X0.8	51,5	36	10	36	M6X1.0	Ø5.2	M5X0.8	138
CCAQ.2030	20	30	96	66	M5X0.8	61,5	36	10	36	M6X1.0	Ø5.2	M5X0.8	158
CCAQ.3210	32	10	60	50	G1/8	43	45	16	48	M6X1.0	Ø5.2	M8X1.25	186
CCAQ.3220	32	20	80	60	G1/8	53	45	16	48	M6X1.0	Ø5.2	M8X1.25	231
CCAQ.3230	32	30	100	70	G1/8	63	45	16	48	M6X1.0	Ø5.2	M8X1.25	281