

N.AP – Standard Blades, 15°

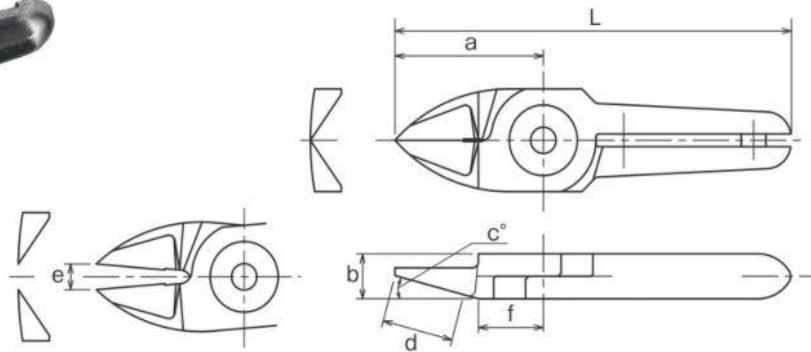

Part No.	a	b	c(°)	d: Effective Length	e: Blade Oppening	f	L	Weight (g)
N5AP	24	7	15	11,5	4	10,5	64	40
N10LAB152	61	12	15	35	10		115	165
N10LAP	35	12	15	16	5	15	89	85
N20AP	35	12	15	16	11	15	95	125
N30AP	66	17	15	38	16	24	150	380

Material: Special Alloy Steel

N.PF – Deep Angle Blades, 30°/40°

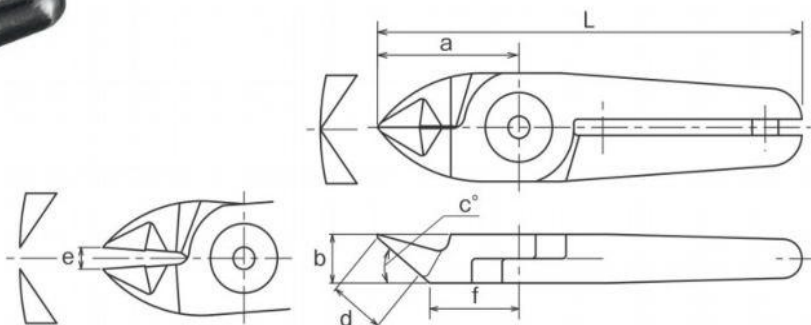

Part No.	a	b	c(°)	d: Effective Length	e: Blade Oppening	f	L	Weight (g)
N10LPF	35	12	40	13,5	5	21	89	120
N20PF	35	12	40	13,5	11	21	95	130
N30PF	58	17	30	25	15	33	142	390
N30AA114	76	17	30	50	20		160	385

Material: Special Alloy Steel