

**LARGE SPRUE GRIPPERS**

**GZ20 – Sprue Grippers GZ20 Series**

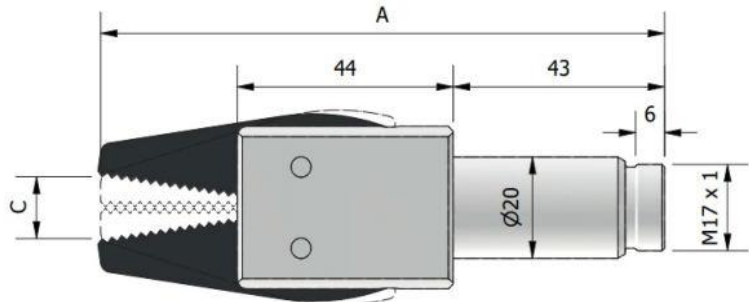
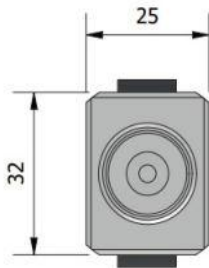

Part No.	Jaw Type	A	C	Sensor Type	Closing Force (6 bar)	Weight (g)
GZ20-10-A	Custom	100	15		90N	114
GZ20-10-E	Curved	115	21		90N	117
GZ20-10-L	Curve-Smooth	115	23		90N	120
GZ20-10-10	Saw Tooth	115	21		90N	121
GZ20-10-10-S	Serrated	115	21	PNP	90N	127
GZ20-10-10-SN	Serrated	115	21	NPN	90N	127
GZ20-10-W-S	Curved	115	21	PNP	90N	123
GZ20-10-W-SN	Curved	115	21	NPN	90N	123

Work principle: Single acting.  
 Working pressure: 6 bar clean and dry air.  
 Material: Jaws made of hard-coated Aluminium. Body made of anodized Aluminium.