

**MINI SPRUE GRIPPERS**

**GZ12-10-8-(Short) – Sprue Grippers 12-10-8 Short Series**

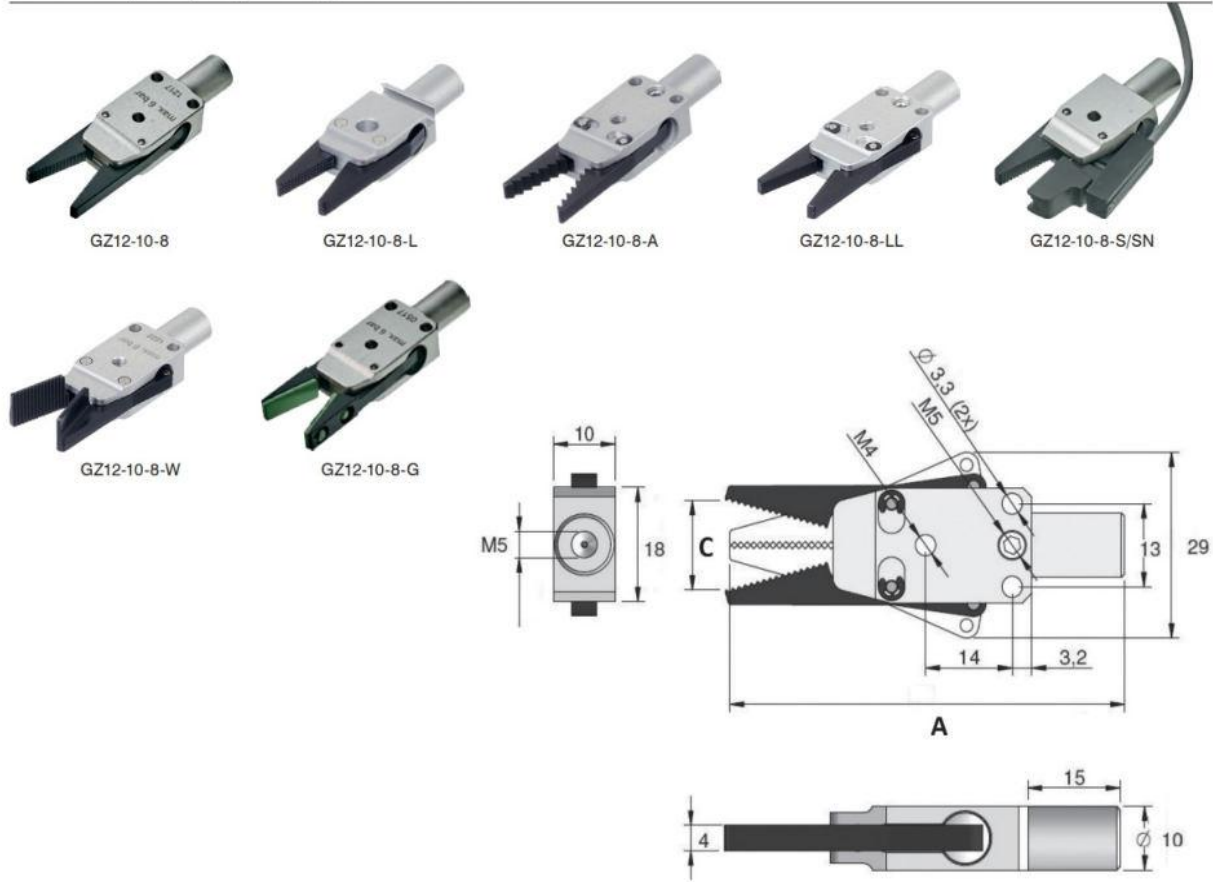

Part No.	C	A	Jaw Type	Sensor	Closing Force (6 bar)	Weight (g)
GZ12-10-8	14	63,9	Serrated	-	19N	30
GZ12-10-8-L	11	59	Diamond Pattern	-	19N	32
GZ12-10-8-A	13	64	Saw tooth	-	19N	30
GZ12-10-8-LL	14	64	Smooth	-	19N	30
GZ12-10-8-W	14	64,1	Extra Wide	-	19N	30
GZ12-10-8-G	14	63,9	Viton rubber Pad	-	19N	30
GZ12-10-8-S	11	61,8	Serrated	PNP	19N	30
GZ12-10-8-SN	11	61,8	Serrated	NPN	19N	30

Compressed air in compliance with ISO 8573-1:2010 [7:4:4].  
Maximum Operating Pressure 8 bar.

**GZ-VIT – Insert Pad, Viton**

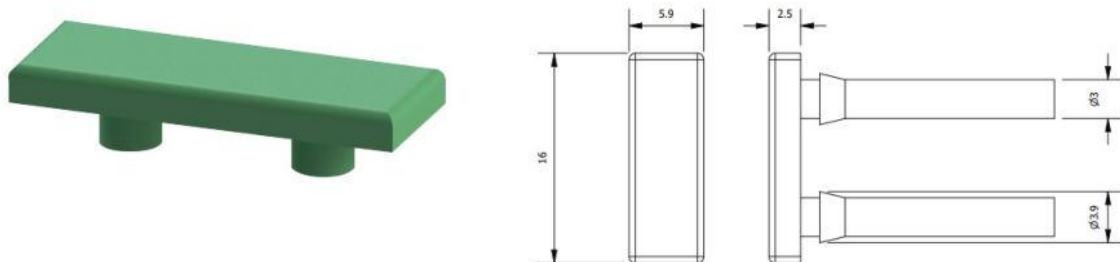

Part No.	Material	REF	Weight (g)
GZ-VIT-4	FKM	GZ12-10-8-G	