



VACUUM CUPS



Mouldpro Multiflex vacuum cups offer outstanding advantages

- Extremely high wear resistance
- Very high lifting force
- Best static friction qualities
- No sticking tendency
- Elasticity remains unchanged for minus temperatures
- Working temperatures from -20°C to + 80°C
- Antimarking

Vacuum Cups - 1,5 Bellow, Ø10-Ø50 mm

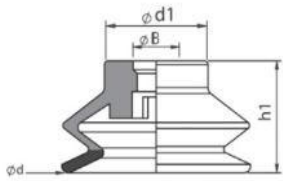
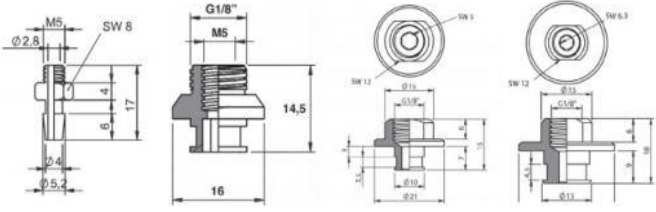
Part No.	d	B	d1	h1	Hardness	Part No.	Part No.	Part No.	Part No.
B15-10MF	5,5	10	3,9	9	16,5	40	F134		
B15-16MF	5,5	16	3,9	9	19	30/60	F134		
B15-20MF	7,6	21	5,2	12	18	30/60		F250	
B15-30MF	7,5	31	6,5	16,8	17	30/60		F251	
B15-40MF	9,3	41	6,3	22,4	22,4	30/60		F251	
B15-50MF	14,4	51	10,5	28	29,2	30/60			F252