

CLAMPS - PROFILE TO COMPONENT

ACLS. – Long Angle Clamp - Swivel Head

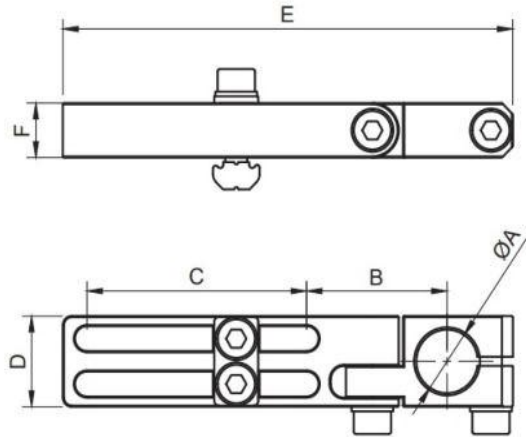

Part No.	A	B	C	D	E	F	Weight (g)
ACLS.1040.X	10	27,5	40	20	86	10	55
ACLS.1460.X	14	32	50	20	102,5	12	67
ACLS.2060.X	20	37,5	60	25	124,5	15	115
ACLS.3080.X	30	50	80	35	166,5	20	254

Material: Aluminium.
 Increased flexibility in component positioning.
 Heavy duty design ensures component stability.

ACLSB. – Long Angle Clamp - Swivel Head and Ball Joint

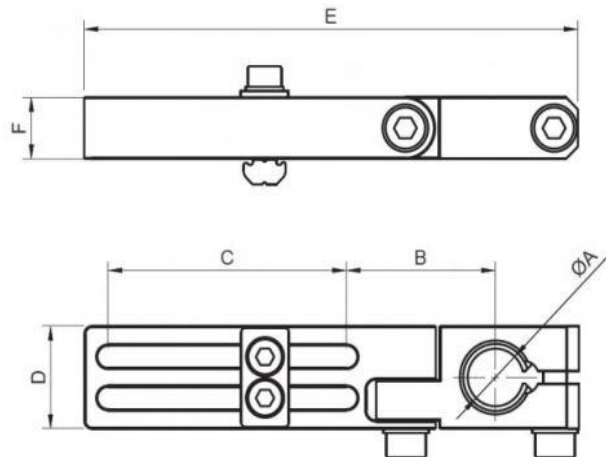

Part No.	A	B	C	D	E	F	Weight (g)
ACLSB.1050.X	10	32	50	20	102,5	12	74
ACLSB.1460.X	14	37,5	60	25	124,5	15	126
ACLSB.2080.X	20	50	80	35	166,5	20	304

Maximum flexibility in component positioning.
 Heavy duty design ensures component stability.