

EJECTOR COUPLINGS

Description

The UKM is a mechanical ejector coupling for plastic injection moulding machines. Its function is to lock the ejector bars of the injection moulding tool.

- The coupling process "locking or unlocking" takes place in only seconds.
- Simple construction - easy to install
- Available with M10 – M12 and M16 thread.

Material:

Steel Type: 1.2510

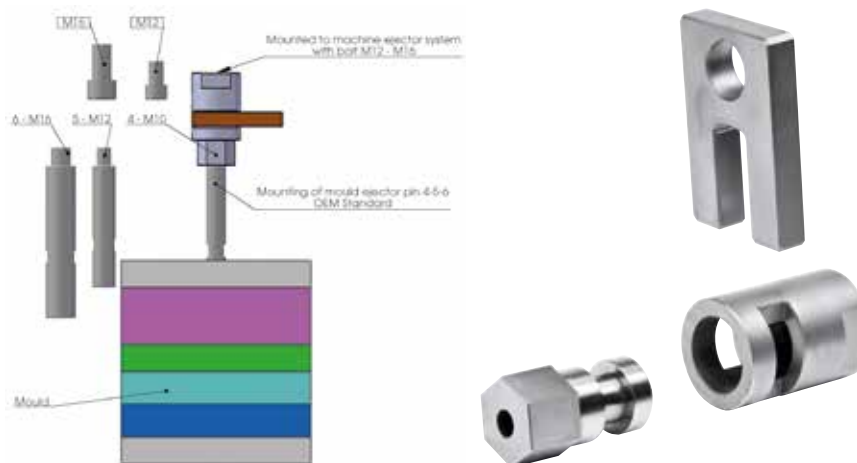

Connector Nipple

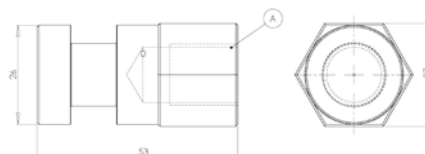

Part No.	A	
UKM10HAN	M10	1
UKM12HAN	M12	1
UKM16HAN	M16	1

Locking Slide

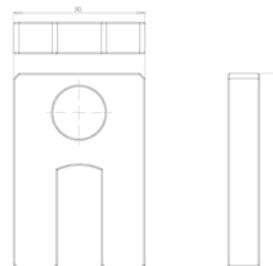

Part No.	SIZE	
UKKILE	ONE SIZE	1

Coupling

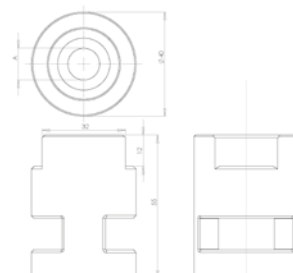

Part No.	A	
UKM12HUN	12	1
UKM16HUN	16	1