

# PNEUMATIC GRIPPERS

## Sprue Gripper GZ12-10-8..(Short)

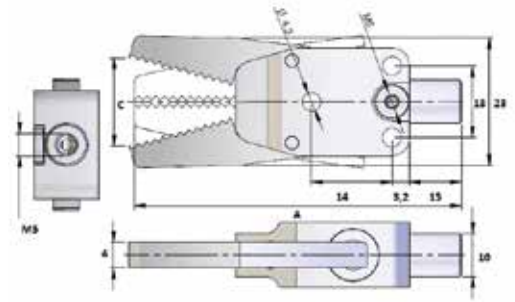
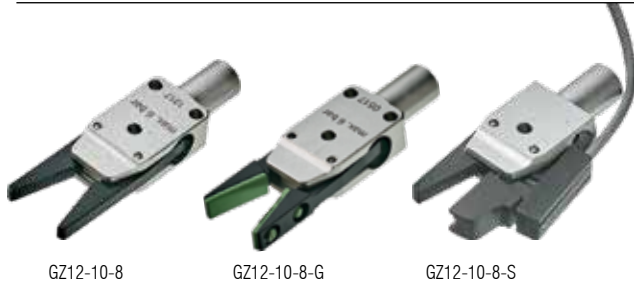

Part No.	C	A	Jaw Type	Sensor Type	Grip Force (6bar)	Weight (g)
GZ12-10-8	14	63,9	Standard Cut		19N	30
GZ12-10-8-G	14	63,9	Viton Rubber		19N	30
GZ12-10-8-S	11	61,8	Standard Cut	PNP (M8)	19N	30

Work principle: single acting.  
 2 different fastening possibilities:  
 Clamp- Ø 10 mm on shaQ / Through-Thread in the gripper body.  
 Working pressure: 6 bar clean and dry air.  
 Material: Jaws made of hardcoated Aluminium. Body made of anodized Aluminium.

## Sprue Gripper GZ12-10-10..(Standard)

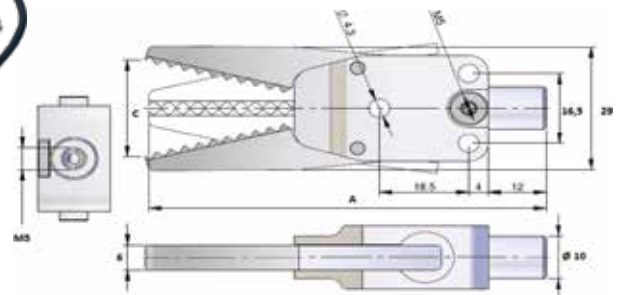

Part No.	C	A	Jaw Type	Sensor Type	Grip Force (6bar)	Weight (g)
GZ12-10-10-M	19,5	75,3	Standard Cut	-	30N	40
GZ12-10-10-L	20,5	75,3	Diamond Cut	-	30N	36
GZ12-10-10-C	17,9	75,3	Curved	-	30N	36
GZ12-10-10-W	20,1	75,3	Wide	-	30N	39
GZ12-10-10-CS	19	75,3	Curved	PNP (M8)	30N	60

Work principle: single acting.  
 2 different fastening possibilities:  
 Clamp- Ø 10 mm on shaQ / Through-Thread in the gripper body.  
 Working pressure: 6 bar clean and dry air.  
 Material: Jaws made of hardcoated Aluminium. Body made of anodized Aluminium.