

Spring loaded Vacuum Cup Arm - Non Rotative

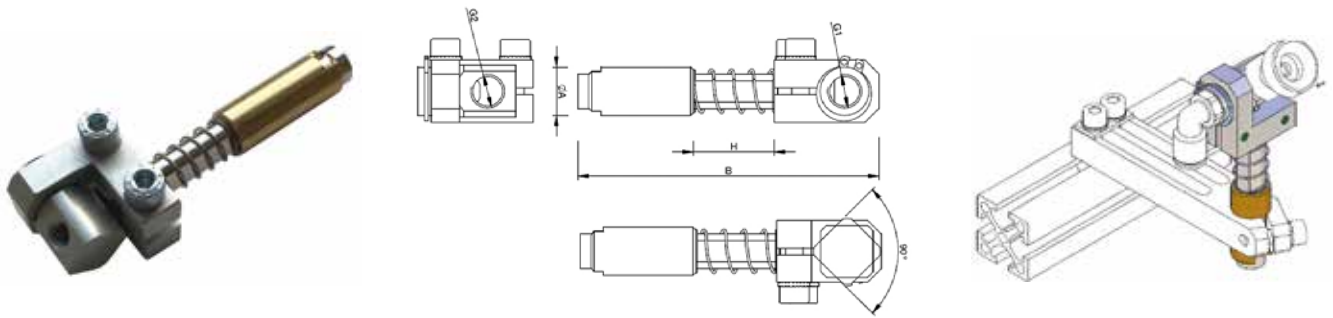

Part No.	A	B	G1	G2	H	F(N)	Weight
MPGGS100515	10	69	M5	M5	10	3.6	37 g
MPGGS100520	10	79	M5	M5	20	6	40 g
MPGGS100530	10	98	M5	M5	30	8.6	45 g
MPGGS141815	14	86	G 1/8	G 1/8	17	20.7	82 g
MPGGS141840	14	110	G 1/8	G 1/8	38	23.3	89 g
MPGGS201425	20	116	G 1/8	G 1/4	23	18.4	196 g
MPGGS201445	20	141	G 1/8	G 1/4	45	16.7	206 g

H= Spring deflection / F= Spring force.

Material: Aluminium.

Guide (tube): Hard coated.

Spring Loaded Level Compensator - Smooth Body - Rotatable

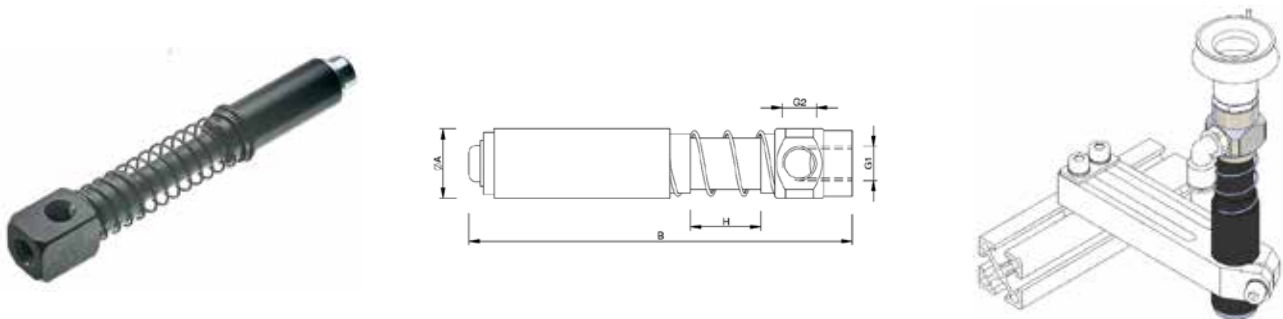

Part No.	A	B	G1	G2	H	F(N)	Weight
MA.GGD.10050510	10	59	M5	M5	10	8	11g
MA.GGD.10050530	10	85	M5	M5	30	11	15g
MA.GGD.14181815	14	84	G1/8	G1/8	15	9	33g
MA.GGD.14181840	14	109	G1/8	G1/8	40	14,6	38g
MA.GGD.20141820	20	109	G1/4	G1/8	20	11,7	76g
MA.GGD.20141850	20	147	G1/4	G1/8	50	16,8	92g

H= Spring deflection / F= Spring force.

• Rotational.

• Extremely light weight Aluminium.

• Tube and shaft hard coated anodizing.