

ColorSave[®]-Micro

Small Dose Gravimetric Feeder



Innovation
In Every Dose

“ Since installing the ColorSave-Micro on our small product line, we have not had a single reject due to color.”

TAVMedical, Contract Manufacturer of Medical Device Components

The only gravimetric feeder designed specifically for small products!



ColorSave-Micro is the only gravimetric feeder that provides consistent accuracy for small doses, while eliminating many of the tasks associated with calibration and maintenance.

Small Dose Accuracy

With accuracy of up to a single pellet, the patented ColorSave-Micro uses a single vibrating channel to accurately and consistently deliver the correct dose.

Easy Calibration & Less Maintenance

Calibration and maintenance time is reduced as the single channel is used for nearly all additives, handles wide range of feed rates and is easily cleaned between jobs.

Nearly all types of additives

ColorSave-Micro supports nearly all additives:

- Pellets
- Several types of regrinds
- Several types of powders
- Micro-granules

Small product manufacturers can finally take a break from manual mixing, difficult calibration, product rejects and over-consumption of masterbatch additive.



ColorSave-Micro Specifications

Feature	Specification
Hopper	640cc
Output Range	up to 80 g/minute
Dosing Technique	Vibration system
Controller	Separate unit with touchscreen display
Communication	Modbus TCP/IP
Weight Resolution	0.01g
Loader	Optional integrated Venturi loader
Mounting & Feeding	Via neckpiece adapter, directly into machine throat
Alarm Output	N/O or N/C dry contact 0V, optional 24V/30mA max.
Weight	Feeder 10 kg, Neckpiece 3.3 kg, Controller 5 kg
Power	100-240V, 50/60 Hz, 20 V/A

ColorSave-Micro Applications

Application Version	Injection Molding	Extrusion	Extrusion Blow Molding
Operation Principle	Batch operation. Online metering and control of additive batches	Continuous operation. Online metering and control of additive flow rate (g/h)	Continuous operation. Online metering and control of additive flow rate (g/h)
Set Point	Setting of desired additive percentage and shot weight	Setting of desired additive flow rate (g/h) or desired percentage from extruder throughput	Setting of desired additive percentage and product weight
Input Signal	Dry contact input for synchronization with plasticizing cycle (and optional with injection cycle)	Dry contact input for synchronization with extruder on/off operation and analog input 0-10v or digital input relative to extruder's speed (rpm)	Dry contact input for synchronization with extruder on/off operation and dry contact input from blowing machine for synchronization with blow cycle
Data Recording	Accumulated number of injection cycles and additive weight	Accumulated data (total additive consumed)	Accumulated total additive consumed in g and number of cycles

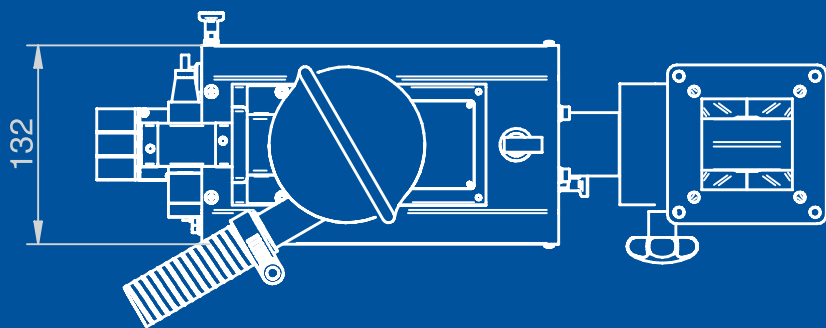
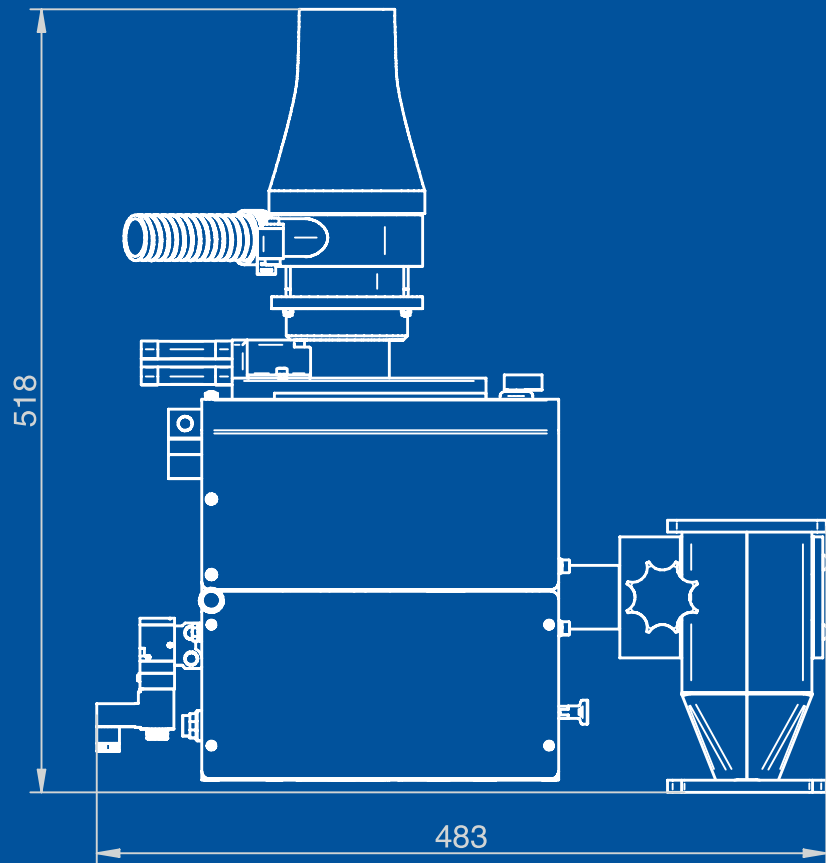

LIAD

An AMPACET Company



Tel: +972-4-9028800 • Fax: +972-4-9028818 • e-mail: prod@liad.co.il
POB 10, Sky St., Misgav Industrial Park 2017400 Israel
www.liad.co.il