

DualSave

Doubling the Savings



 **LIAD**
An AMPACET Company

Innovation
In Every Dose

Totally accurate and cost-effective, DualSave is a dosing system able to regulate two feeders connected to the same neckpiece with a single control unit. Utilizing propriety design and algorithms based on LIAD's single channel feeder "ColorSave", DualSave ensures consistent feeding when working with a variety of materials. DualSave can be configured for either weight or volumetric feeder, and can be used for injection molding, extrusion or extrusion blow molding applications.

DualSave Advantages

- Unparalleled accuracy and precision
- Easy and intuitive control unit
- Unmatched cost-savings
- Improved quality of final product
- Vastly reduces the amount of rejects
- Stores up to 500 recipes, shortening setup time
- Easy replacement of feeding screw
- Ability to combine gravimetric and volumetric channels
- Compensation of masterbatch amount when using scrap material

Multiple Applications

DualSave can be used for the following applications:

- Injection molding
- Extrusion
- Extrusion blow molding

Part Number Principle

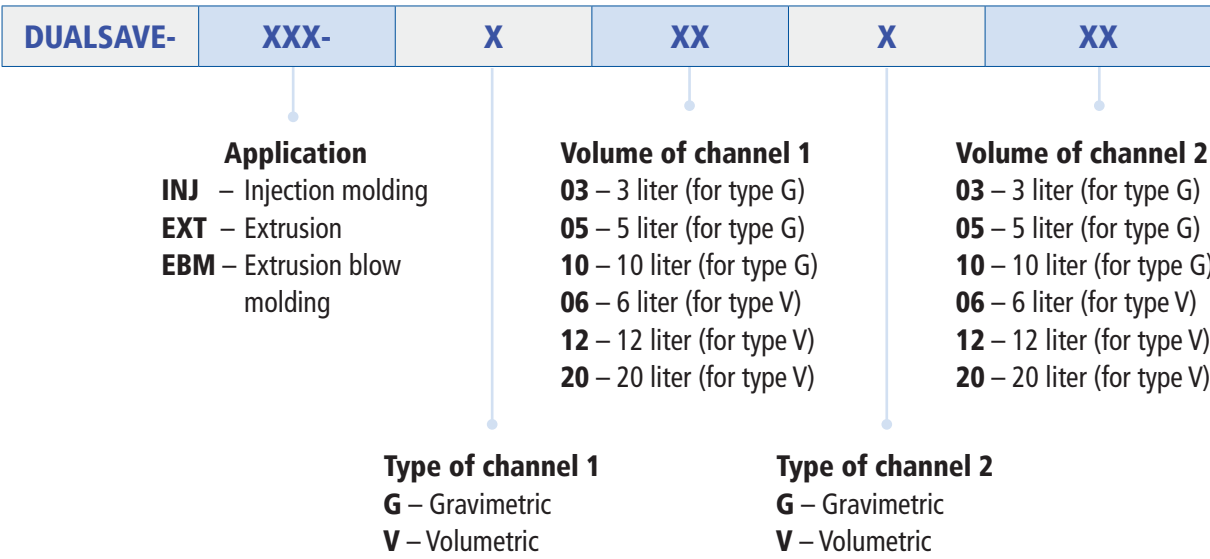

DualSave Specifications

Feature	Specification
Hopper Volume	3/5/10 liter with gravimetric channel 6/12/20 liter with volumetric channel
Output range	0.2-100 kg/h with gravimetric channel 0.02-200 kg/h with volumetric channel
Motor	Powerful step motor
Display	7" color touch screen
Input signals - Injection molding	Dry contact for synchronization with plasticization cycle, optional dry contact for synchronization with injection cycle
Input signals - Extrusion	Dry contact for synchronization with extruder on/off operation, synchronization using analog input 0-10V or 24V digital tachometer
Input signals - Blow molding	Dry contact for synchronization with extruder on/off operation, dry contact for synchronization with mold cycle
Recipes	500
Communication	Modbus TCP/IP Included in injection molding and blow molding applications, optional in extrusion application
Load cell	15 kg for 3 or 5 liter volume, 30 kg for 10 liter volume Temperature compensated
Loader	Optional automatic integral Venturi vacuum loader
Mounting and feeding	By neckpiece adapter, directly into the machine throat
Alarm output	N/O or N/C dry contact 0V, optional 24V/30mA max.
Power	100-240v, 200W, 50/60hz

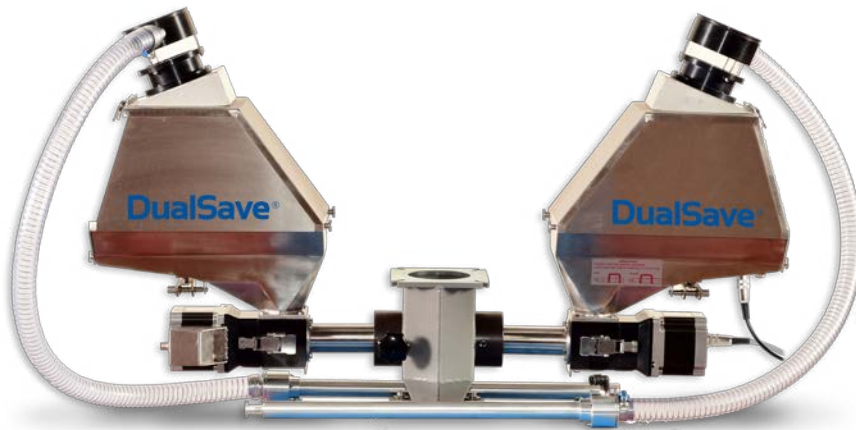

DualSave gravimetric 3L with gravimetric 3L

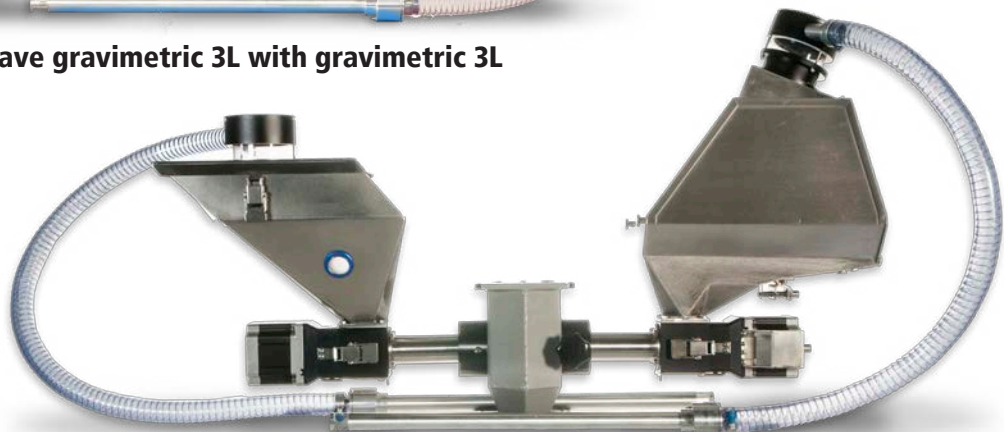

DualSave gravimetric 3L with volumetric 6L

DualSave Compensation Feature

The DualSave controller contains a built-in feature called "Compensation" that can be used when one of the channels is volumetric and feeding scrap material and the other channel is feeding masterbatch either by gravimetric or volumetric channel.

As the scrap material already contains masterbatch it is possible to reduce the amount of masterbatch to be used in the other channel. This provides substantial production cost savings.

For example, if a recipe calls for 5% masterbatch in one channel and 20% scrap material in the other channel, DualSave automatically reduces the masterbatch percentage to 4%. By the same instance increasing the scrap to 40% reduces the masterbatch to 3%.

Using a capacity sensor in the scrap channel ensures that when there is no more scrap material the percentage of the masterbatch returns to its original percentage.

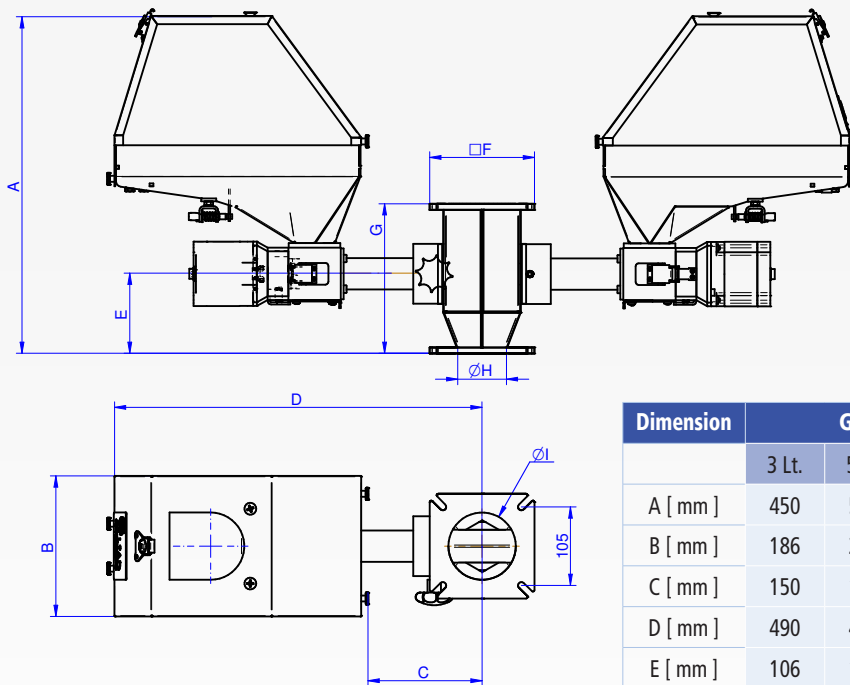

Dimension	Grav.			Vol.		
	3 Lt.	5 Lt.	10 Lt.	6 Lt.	12 Lt.	20 Lt.
A [mm]	450	500	530	385	455	520
B [mm]	186	210	250	194	310	285
C [mm]	150	150	128	159	161	135
D [mm]	490	490	537	498	550	658
E [mm]	106	106	95	106	106	95
F [mm]	140	140	140	140	140	140
G [mm]	200	200	200	200	200	200
H [mm]	40 (65)	40 (65)	70 (128)	40 (65)	40 (65)	70 (128)
I [mm]	90	90	128	90	90	128



Tel: +972-4-9028800 • Fax: +972-4-9028818 • e-mail: prod@liad.co.il
 POB 10, Sky St., Misgav Industrial Park 2017400 Israel
www.liad.co.il