

# AIRTECT

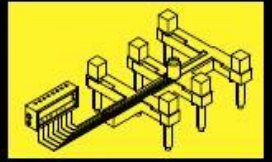

*Plastic Leak Alarm System*

**DETECT YOUR NOZZLE AND  
HOT RUNNER LEAKS EARLY!**

**REPRESENTED BY:**

**4Moulding**

benodigdheden voor kunststofverwerking

DESIGNED AND MANUFACTURED BY:

G.K.E Ltd t/a KENEX, E5 Swords Enterprise Park, Feltrim Road, Swords, Co. Dublin IRELAND Tel:+353 87 2996101

[info@airtect.com](mailto:info@airtect.com) [www.airtect.com](http://www.airtect.com)

# AIRTECT

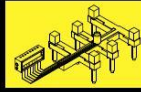

Plastic Leak Alarm System

## WHAT IS AIRTECT?

THE AIRTECT PLASTIC LEAK ALARM SYSTEM IS A UNIQUE DEVICE WHICH ASSISTS IN PREVENTING DAMAGE CAUSED BY LEAKING MOLTEN PLASTIC MATERIAL AT THE MAIN INJECTION NOZZLE OF INJECTION MOULDING MACHINES AND ALSO WITHIN HOT RUNNER MOULDS.

IT IS BEING USED WORLDWIDE BY MANY WELL KNOWN COMPANIES SUCH AS IAC, VALEO, MAGNA, BD, HELLA, POLYPIPE... TO NAME BUT A FEW.

AIRTECT PRODUCTS ARE REPRESENTED WORLDWIDE BY A NETWORK OF DISTRIBUTORS.



# AIRTECT

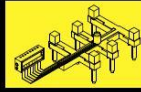

*Plastic Leak Alarm System*

## WHY USE AIRTECT?

Because of an industry wide problem.....Leaks of molten Plastic Material at the Main Injection Nozzle and within Hot Runner Moulds:



# AIRTECT

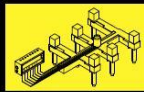

Plastic Leak Alarm System

BECAUSE OF THIS!



# AIRTECT

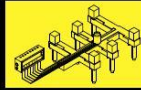

*Plastic Leak Alarm System*

AND THIS.....!

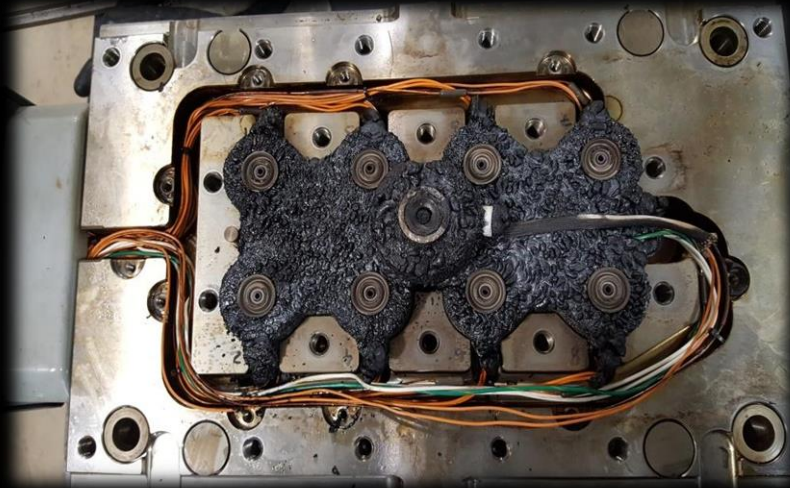

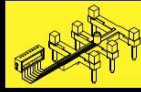

## WHAT ARE THE COSTS OF NOZZLE LEAKS?

The tangible costs include replacement heater bands and thermocouples, maintenance labour and machine downtime.

(intangible costs can be reputational damage due to late deliveries and health and safety issues)

### NOZZLE LEAK COST

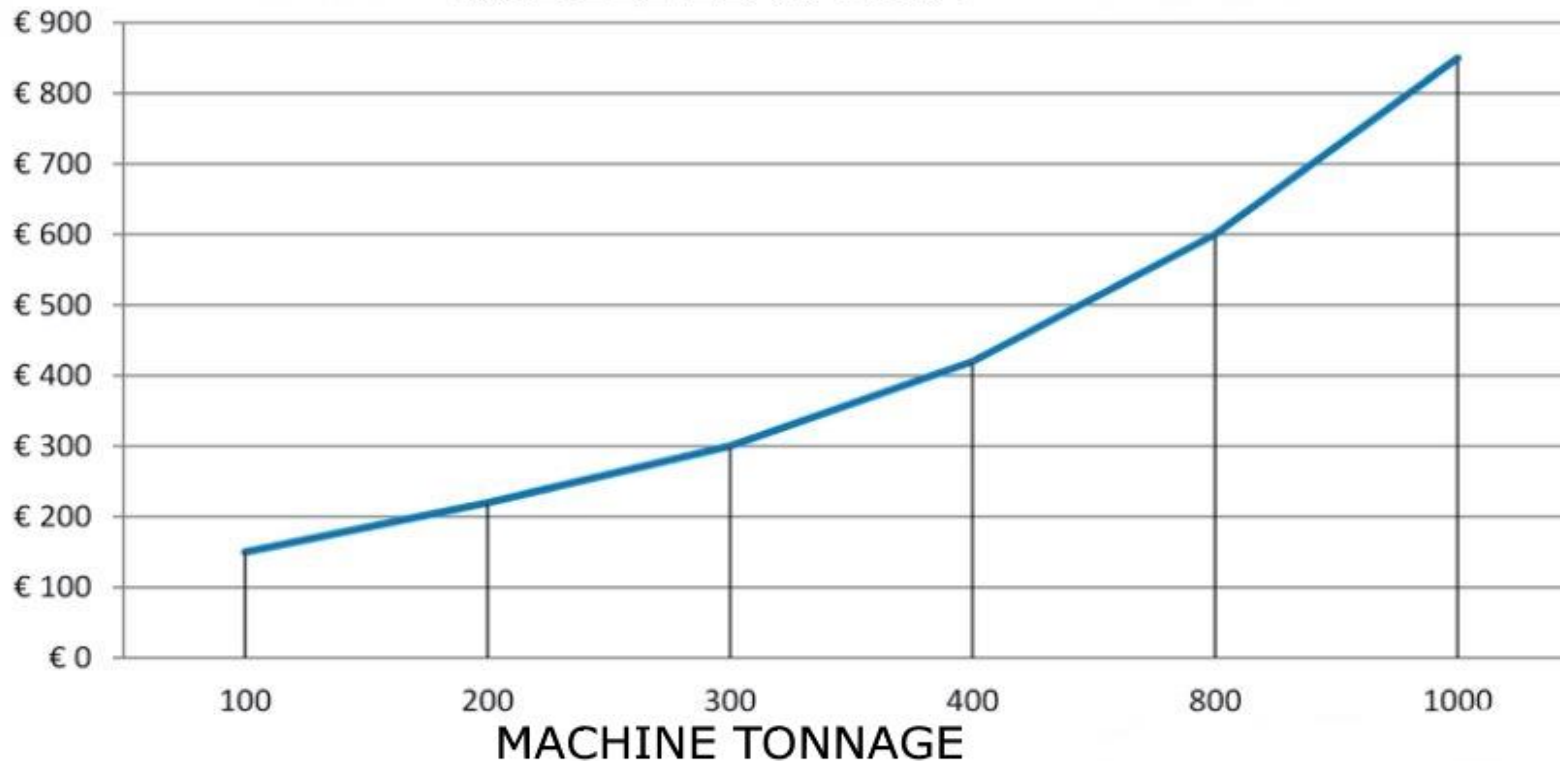

# AIRTECT

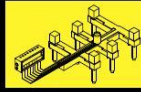

Plastic Leak Alarm System

DETECT YOUR NOZZLE AND HOT RUNNER LEAKS EARLY!! ☺

PRINCIPLE OF OPERATION.....

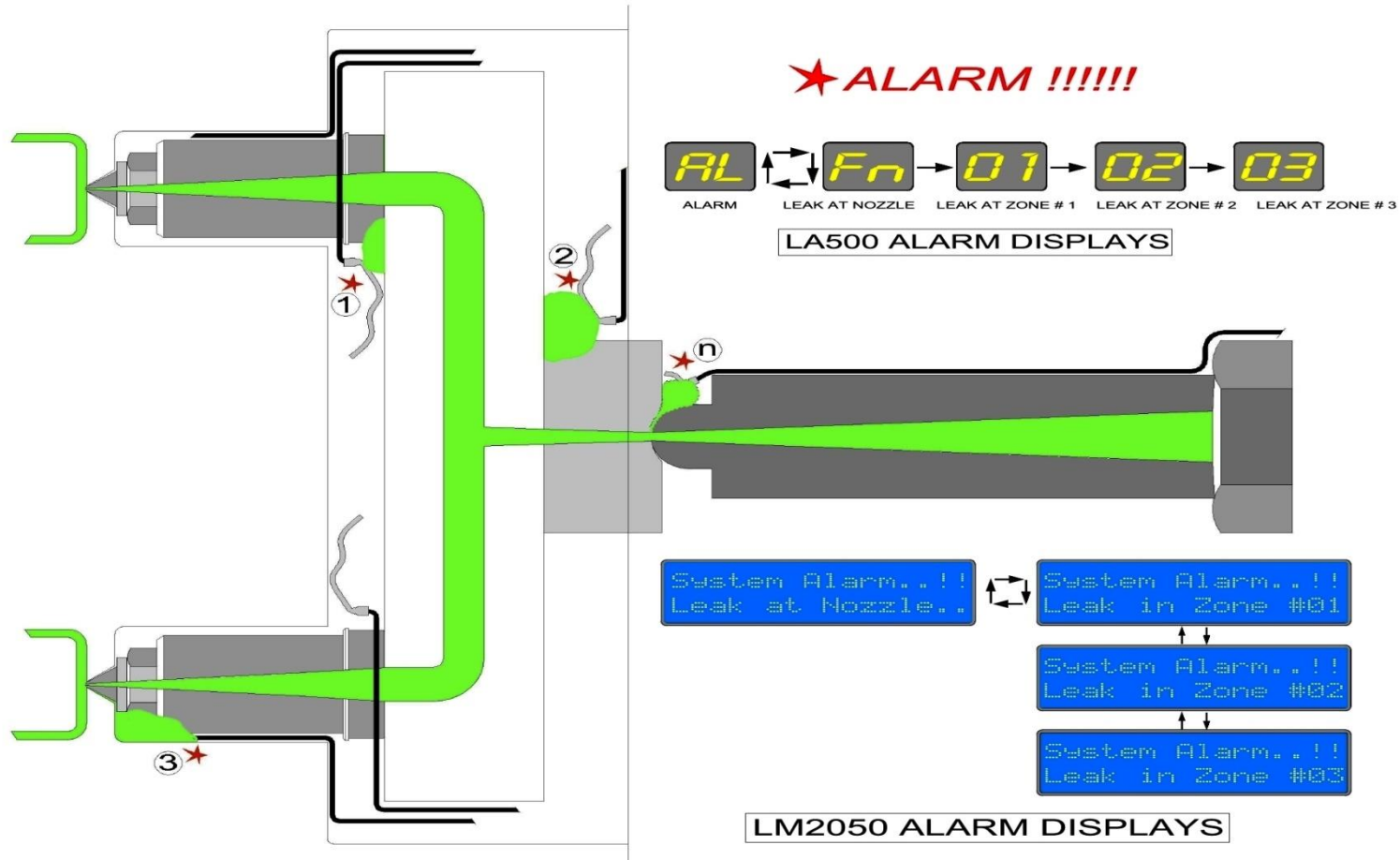

Control/Display Units

4, 8 and 16-Zone Manifolds + Stand-Alone Manifolds

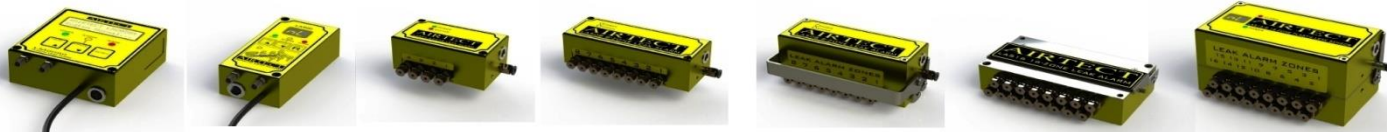



IS THERE ANY  
SOLUTION? TRY THESE 😊

**A PROVEN EFFECTIVE SOLUTION TO REDUCE THE DAMAGE  
AND COST OF THESE LEAKS.....**

LA500



LM2050



## BENEFITS:

- Nozzle and Barrel Protection 😊
- Significantly Reduced Budget for Maintenance Items 😊
- Increased Health and Safety 😊
- Reduced Downtime 😊
- Peace of Mind for Unattended Machines 😊



# AIRTECT

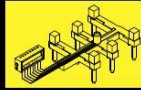

Plastic Leak Alarm System

**LA500**

Functions as an Injection Nozzle Leak Alarm + Display and Control Unit and can be connected to Multi-Zone Manifold Units for Hot Runner Leak Detection.



## INJECTION NOZZLE PLASTIC LEAK ALARM (AND CONTROL UNIT FOR LA508/516 MANIFOLD)

### Kit Includes:

- LA500 with 2 x 7-segment LED display with programmable operational settings
- AR-20GF Air Pressure Regulator with Pressure Gauge, Air Filter and Fittings
- 3 Meters PU Tube
- 0.5 Metres 2.5mm Silicone Rubber Tube
- 3 Meters 2mm Stainless Steel Sensor Tube
- Installation/Operation Manual
- 2 Meter Electrical Power/Interlock Cable

# AIRTECT

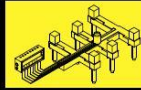

Plastic Leak Alarm System

**LM2050**

Functions as an Injection Nozzle Leak Alarm + Display and Control Unit and can be connected to Multi-Zone Manifold Units for Hot Runner Leak Detection.



## INJECTION NOZZLE PLASTIC LEAK ALARM (AND CONTROL UNIT FOR LA508/516 MANIFOLD)

### Kit Includes:

- LM2050 with Clear Text LCD display with programmable operational settings
- AR-20GF Air Pressure Regulator with Pressure Gauge, Air Filter and Fittings
- 3 Meters PU Tube
- 0.5 Metres 2.5mm Silicone Rubber Tube
- 3 Meters 2mm Stainless Steel Sensor Tube
- Installation/Operation Manual
- 3 Meter Electrical Power/Interlock Cable

# AIRTECT

Plastic Leak Alarm System

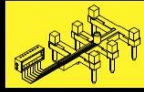

**LA500 INSTALLATION**  
(for nozzle only leak detection)

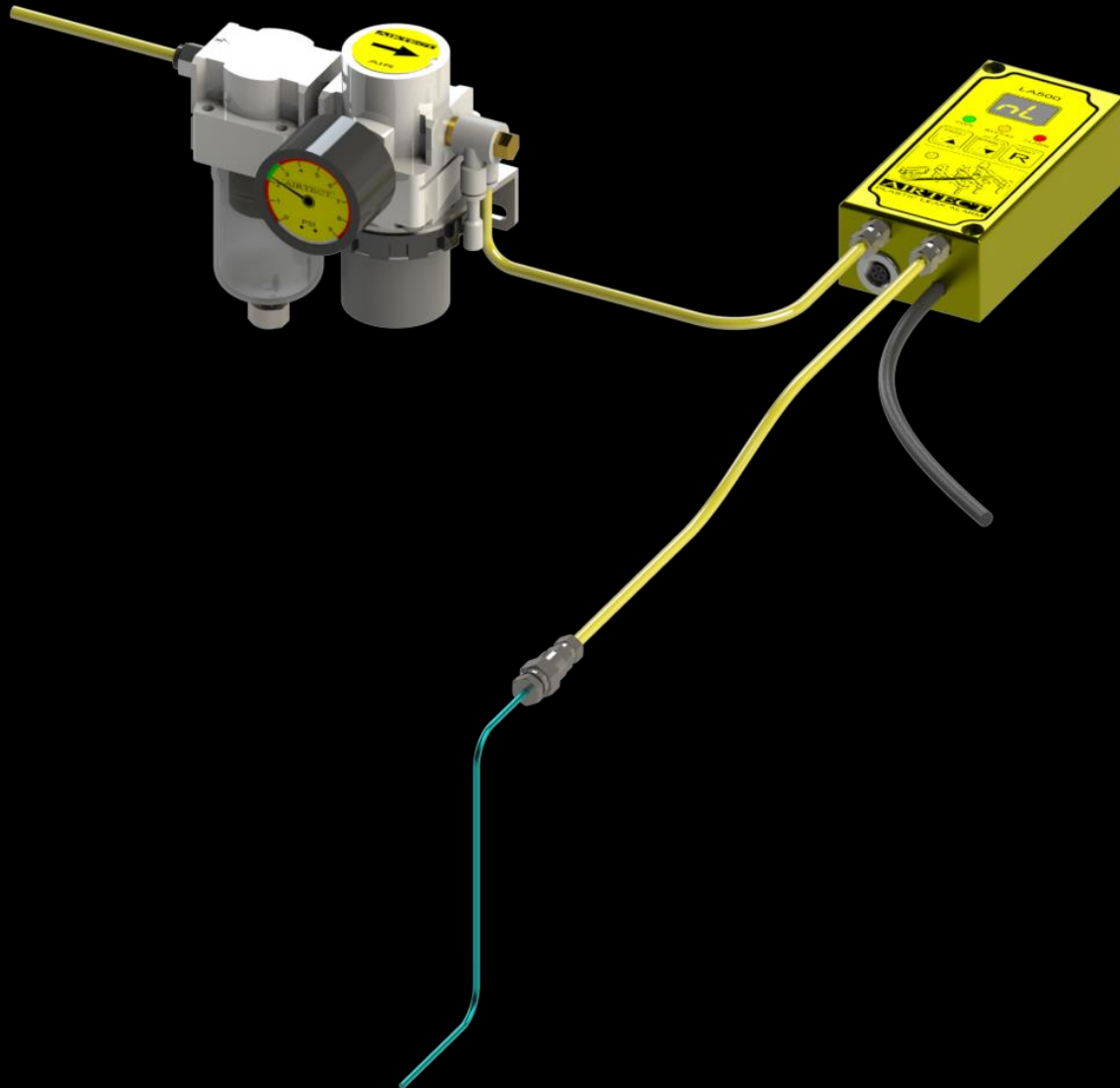

# AIRTECT

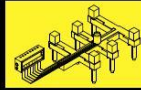

*Plastic Leak Alarm System*

**LA500 PRACTICAL INSTALLATION**  
(for nozzle only leak detection)



# AIRTECT

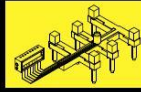

Plastic Leak Alarm System

**LM2050 INSTALLATION**  
(for nozzle only leak detection)

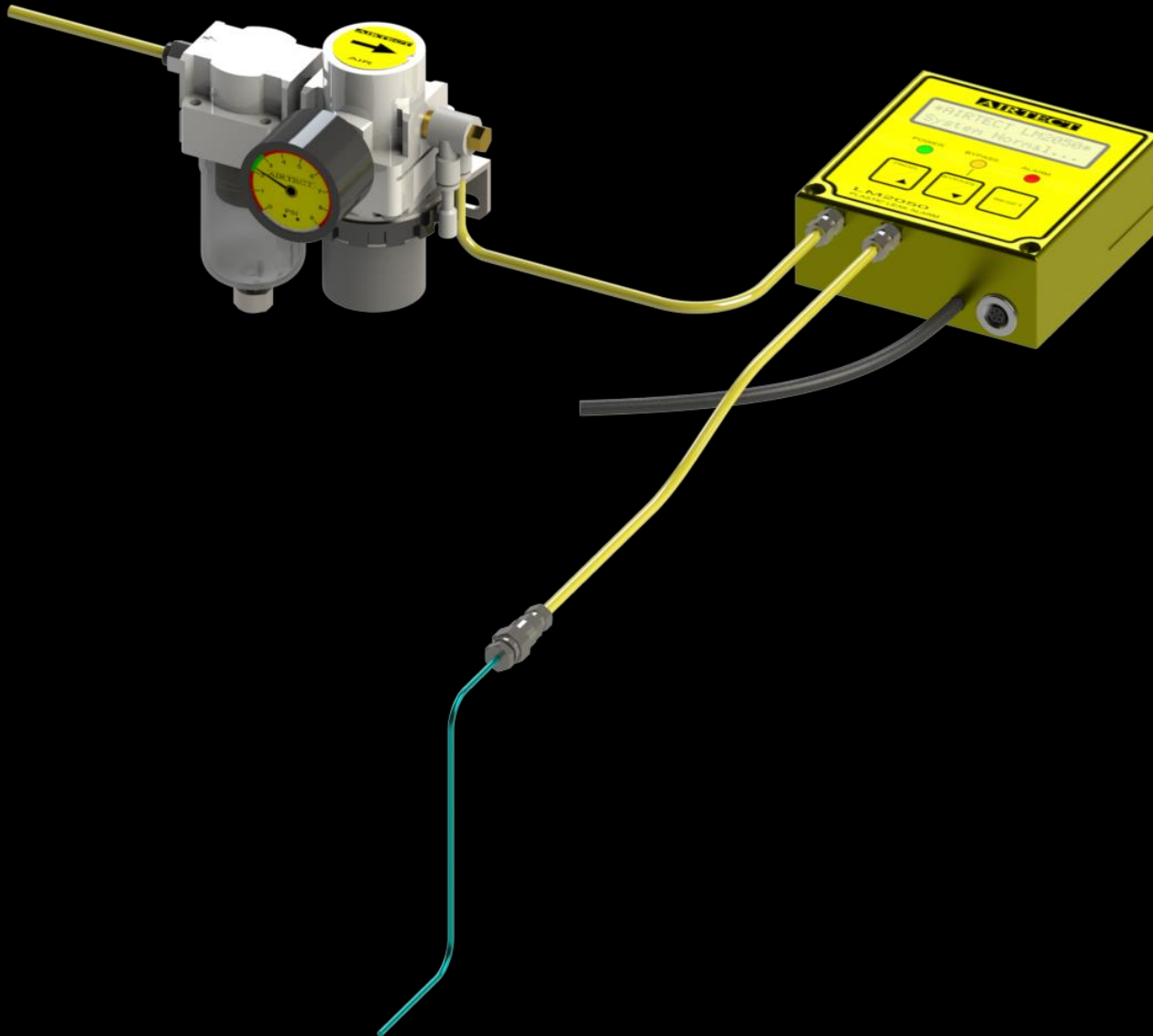

# AIRTECT

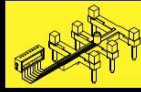

*Plastic Leak Alarm System*

**LM2050 PRACTICAL INSTALLATION**  
(for nozzle only leak detection)

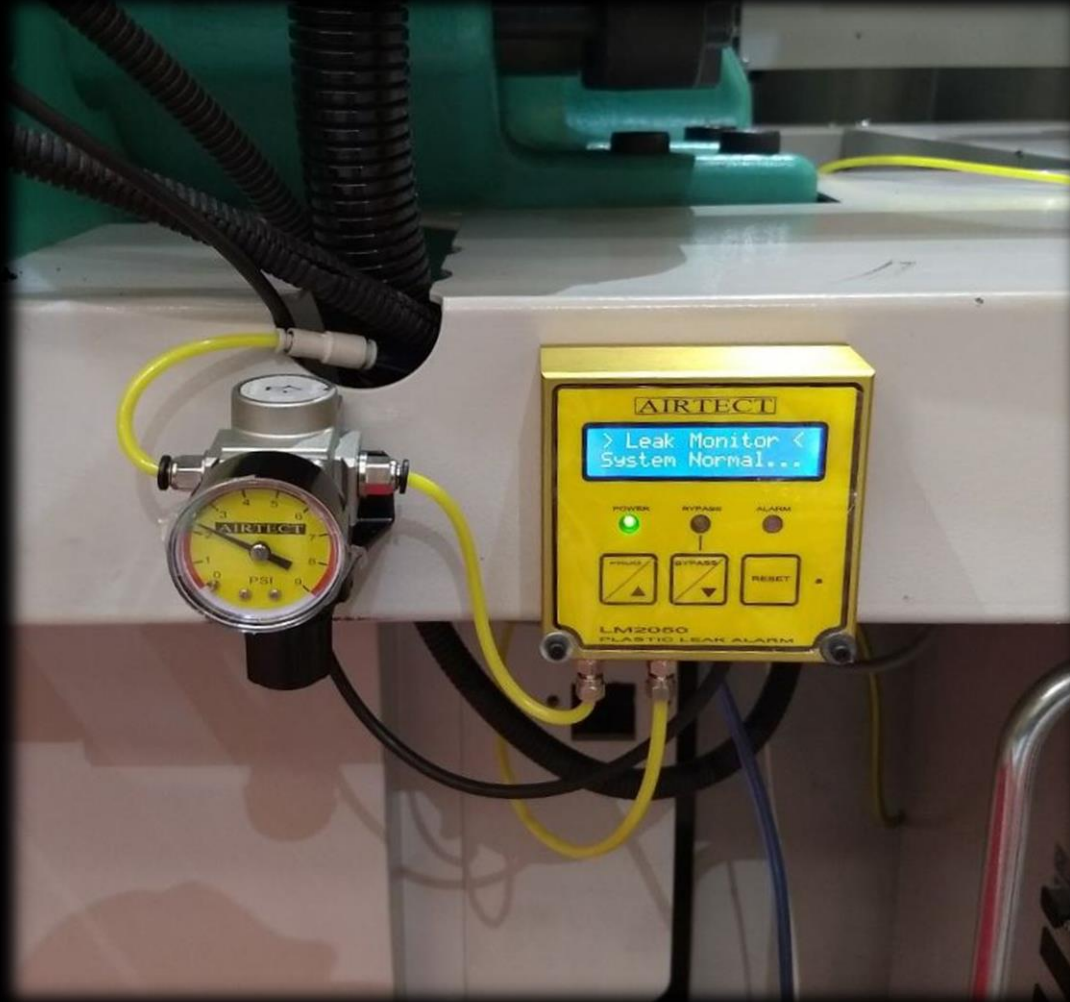

# AIRTECT

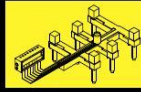

Plastic Leak Alarm System

## LM2050 and LA500 NOZZLE SENSOR TUBE INSTALLATION

FULL CUTTING RECOMMENDATIONS SHOWN LATER

1. File Sensor Tube Flat
2. Ensure 1mm Clear Hole in Centre
3. Put on Silicone Rubber Sleeve

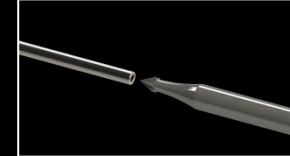
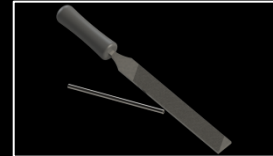
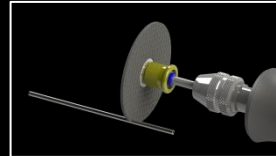

4. Place close to nozzle...customer can decide depending on how soon an indication they need.
  5. Fix the Sensor Tube securely!
- (leave 15-20mm overhang and keep away from direct contact with heater band or nozzle, max 270°C)

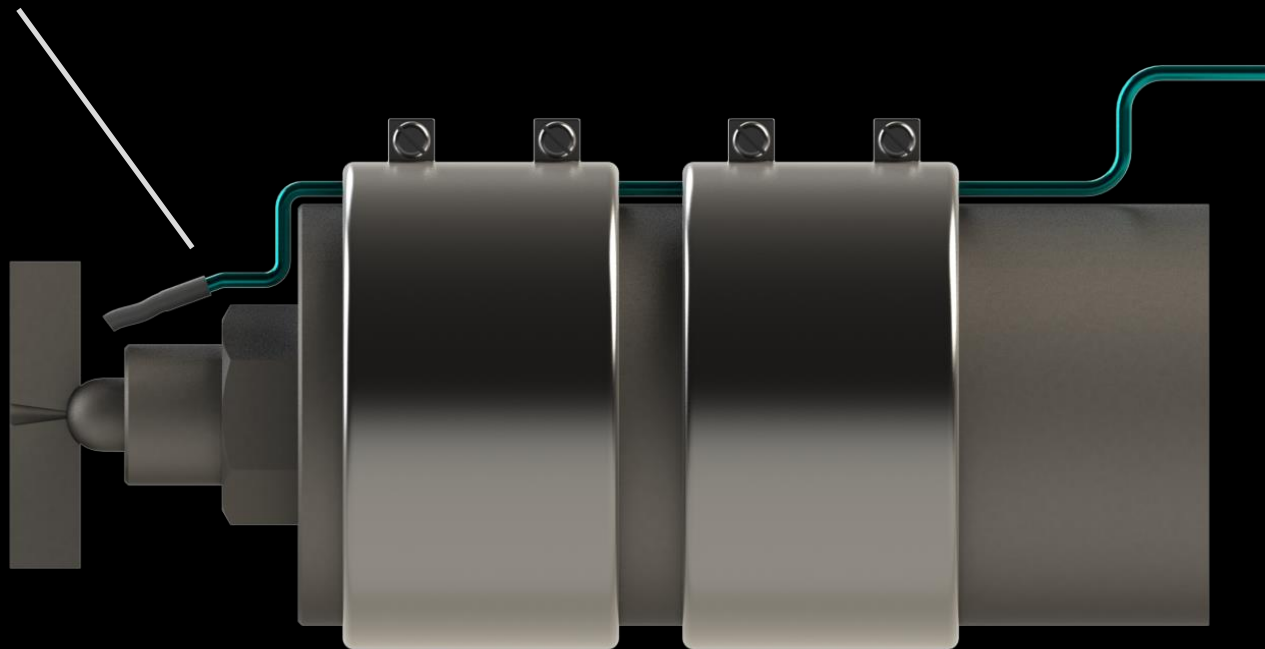

# AIRTECT

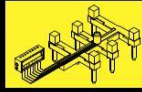

*Plastic Leak Alarm System*

**LM2050 and LA500 NOZZLE  
SENSOR TUBE INSTALLATION**

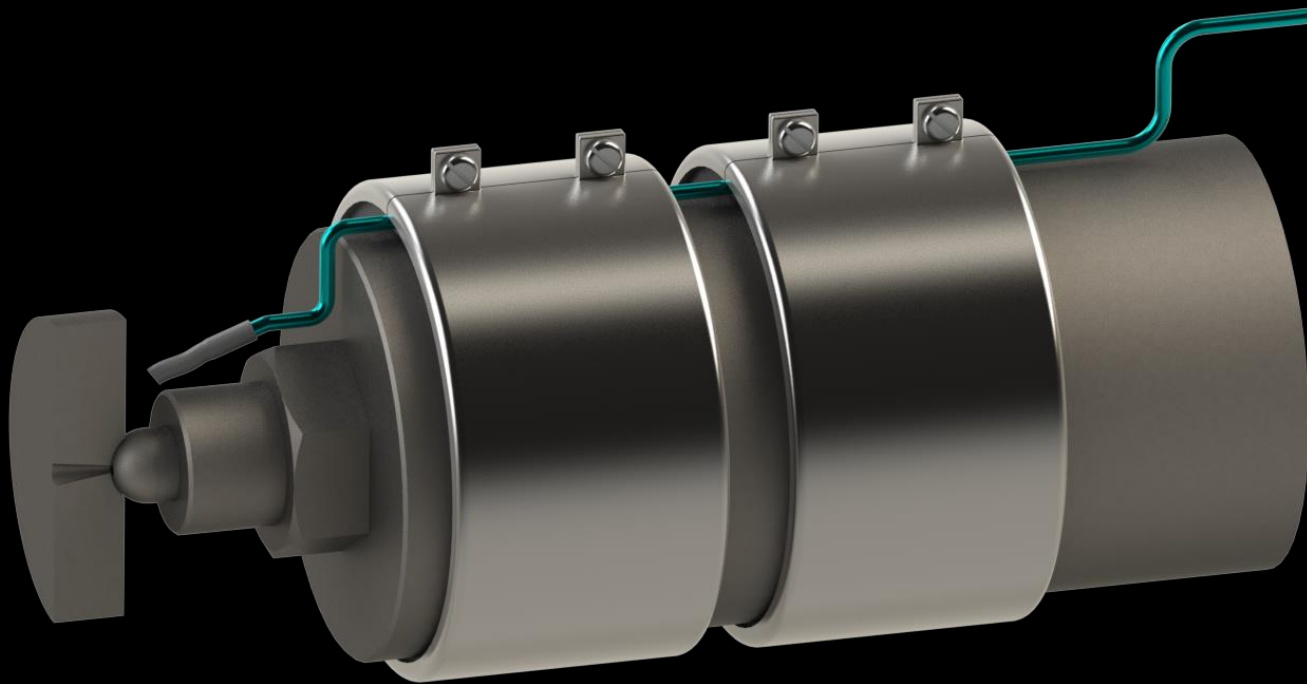



# AIRTECT

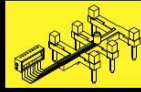

*Plastic Leak Alarm System*

**LM2050 and LA500 PRACTICAL  
SENSOR TUBE INSTALLATION**



# AIRTECT

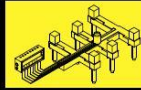

Plastic Leak Alarm System

## LM2050, and LA500 ELECTRICAL INSTALLATION (single nozzle and multi-zone)

### NPN SYSTEM

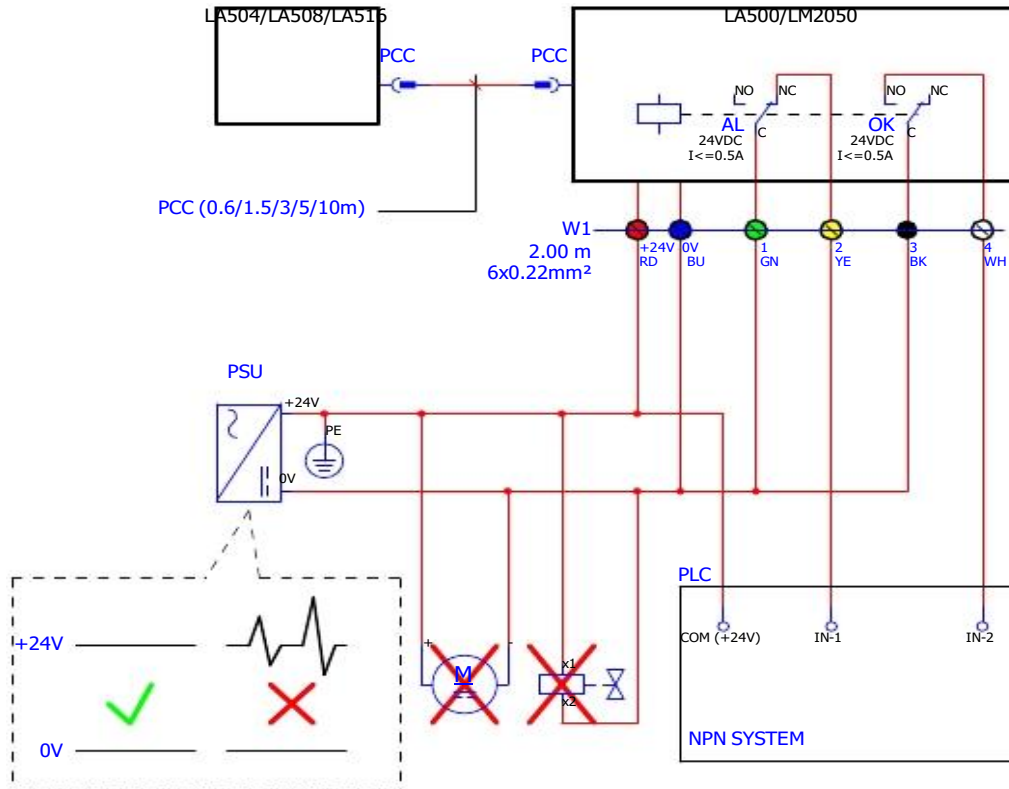

LA500



LM2050

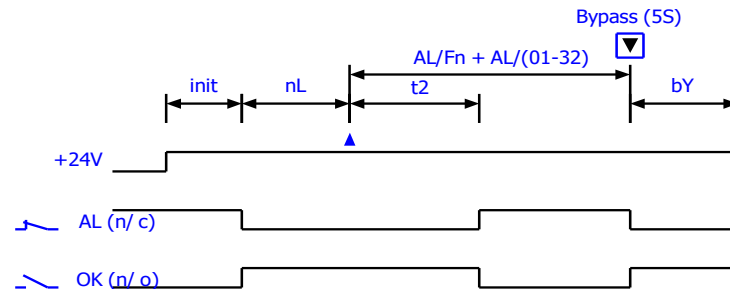
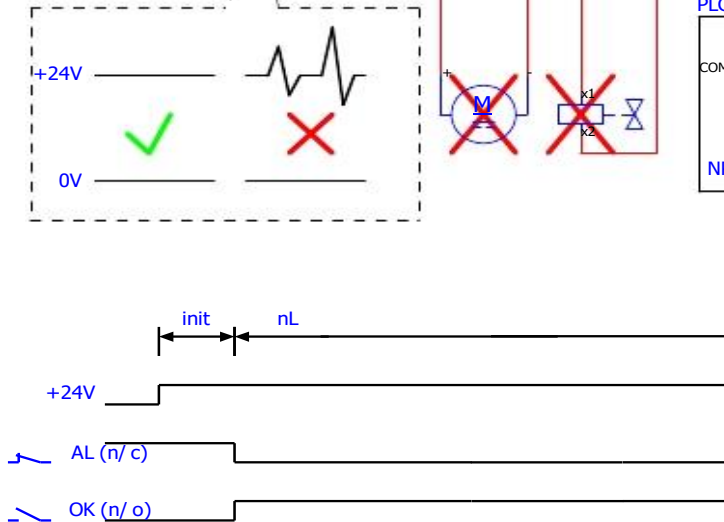
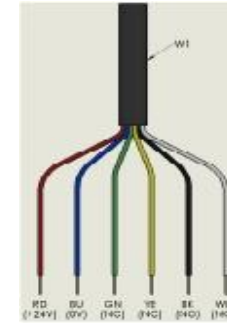

# AIRTECT

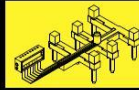

Plastic Leak Alarm System

## LM2050, and LA500 ELECTRICAL INSTALLATION (single nozzle and multi-zone)

### PNP SYSTEM

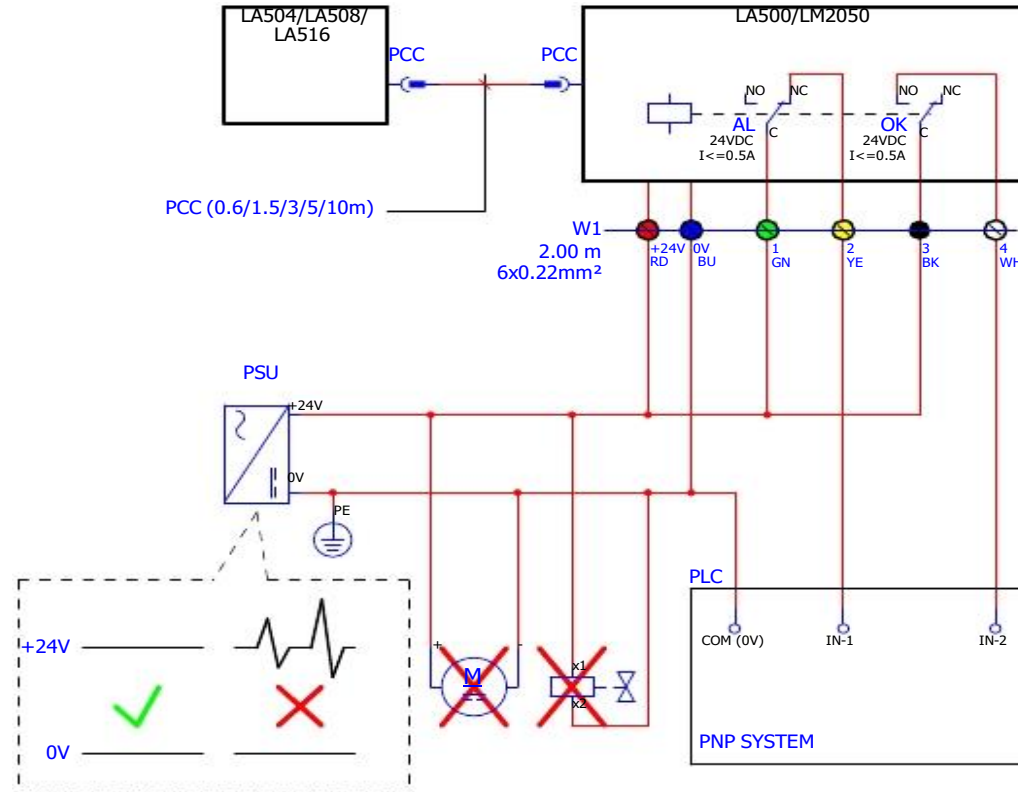

LA500



LM2050

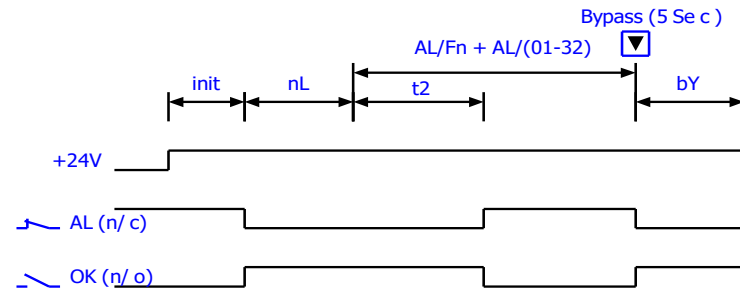
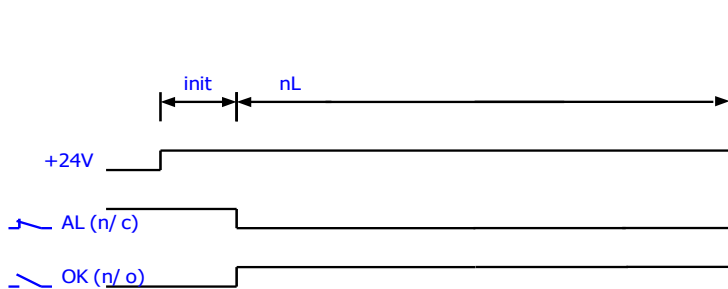
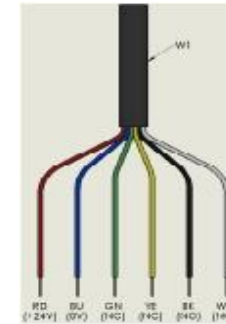

# AIRTECT

Plastic Leak Alarm System

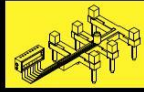

## LM2050, and LA500 ELECTRICAL INSTALLATION (single nozzle and multi-zone)

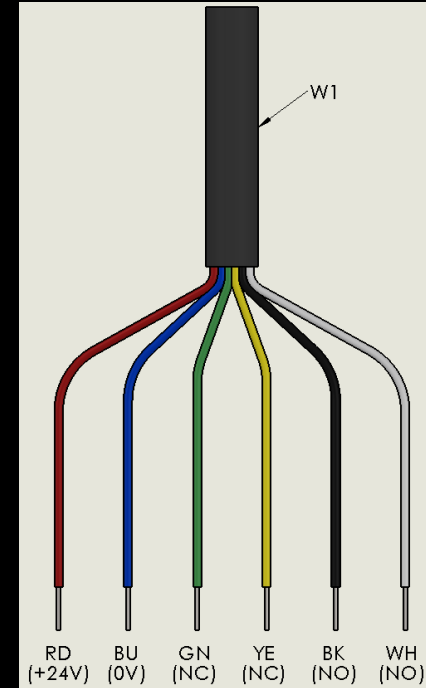
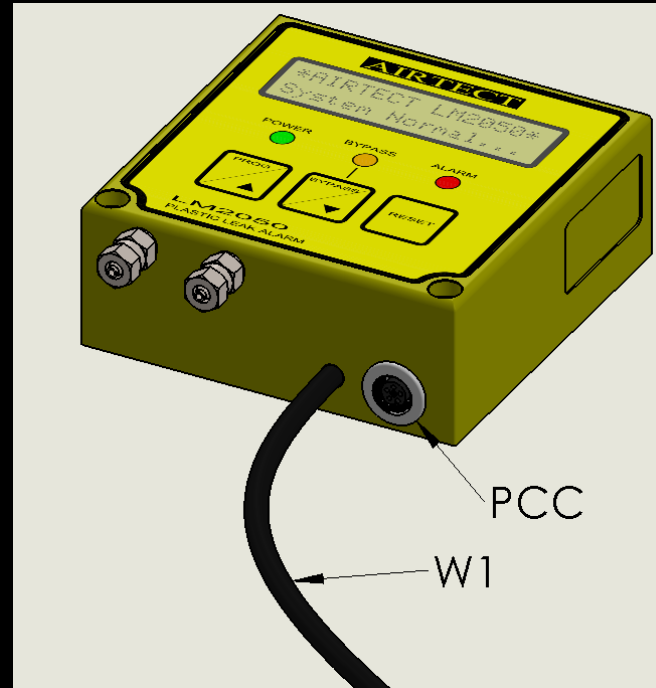
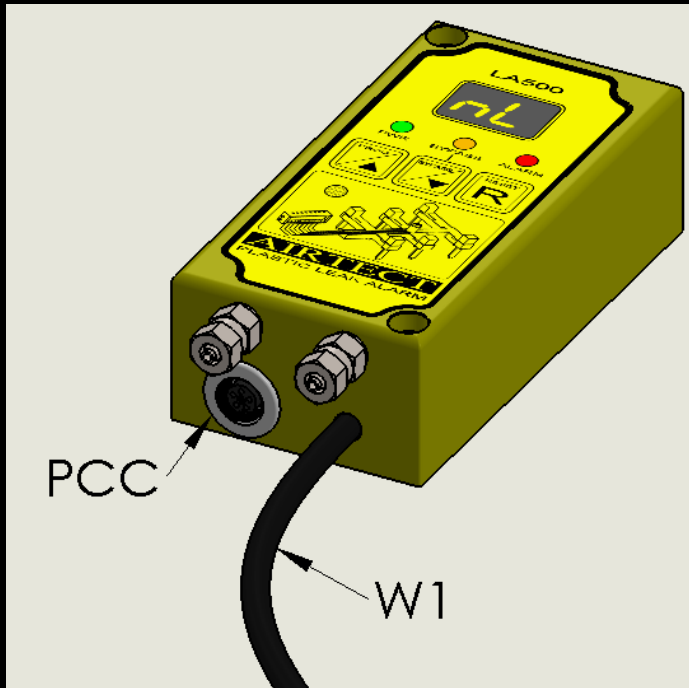

# AIRTECT

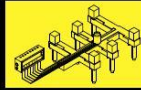

Plastic Leak Alarm System

**LM2050 INSTALLATION**  
(single nozzle and 8-zone leak detection)

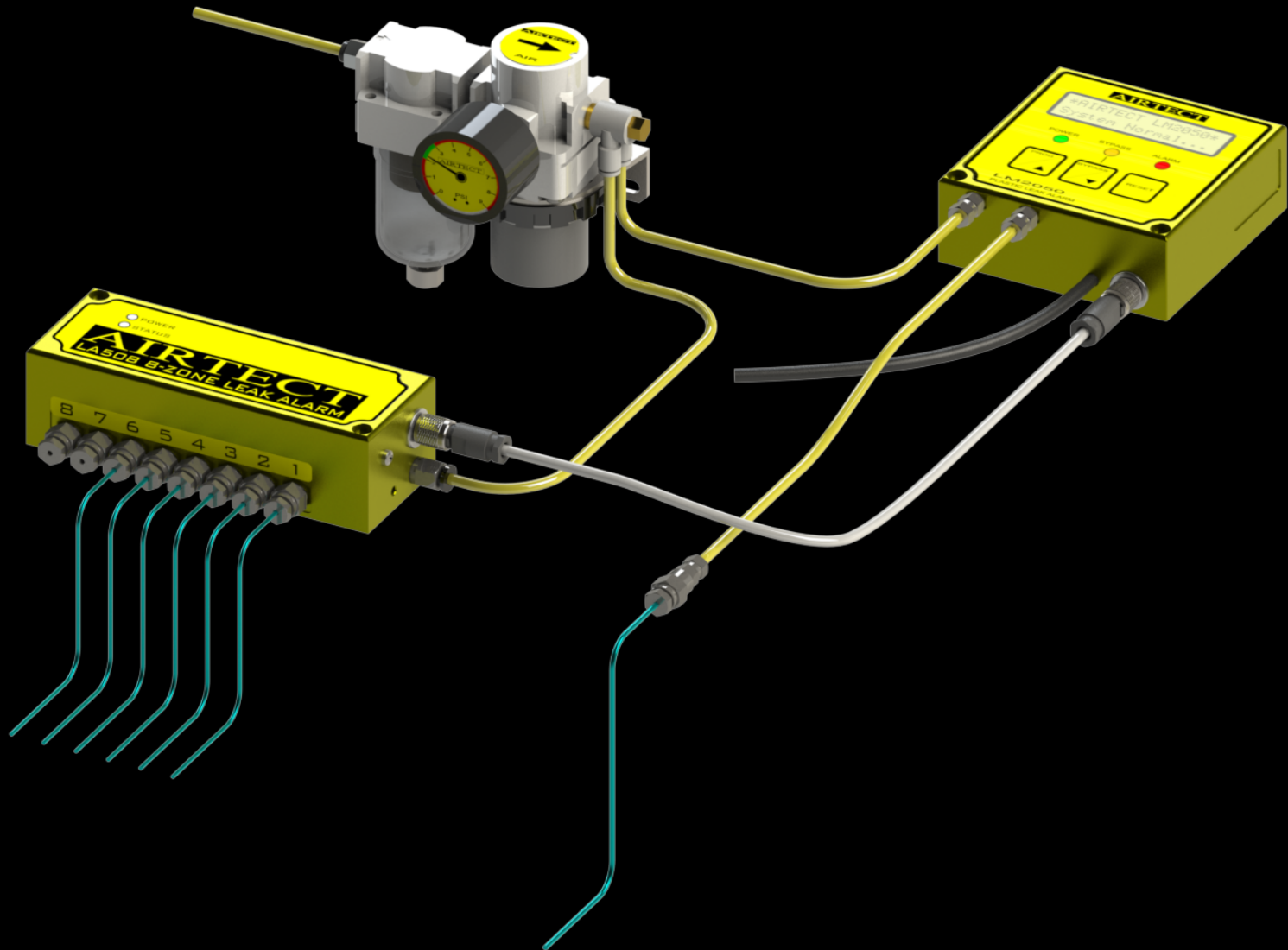

# AIRTECT

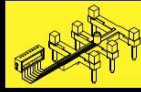

Plastic Leak Alarm System

**LM2050 INSTALLATION**  
(single nozzle and 32-zone leak detection)

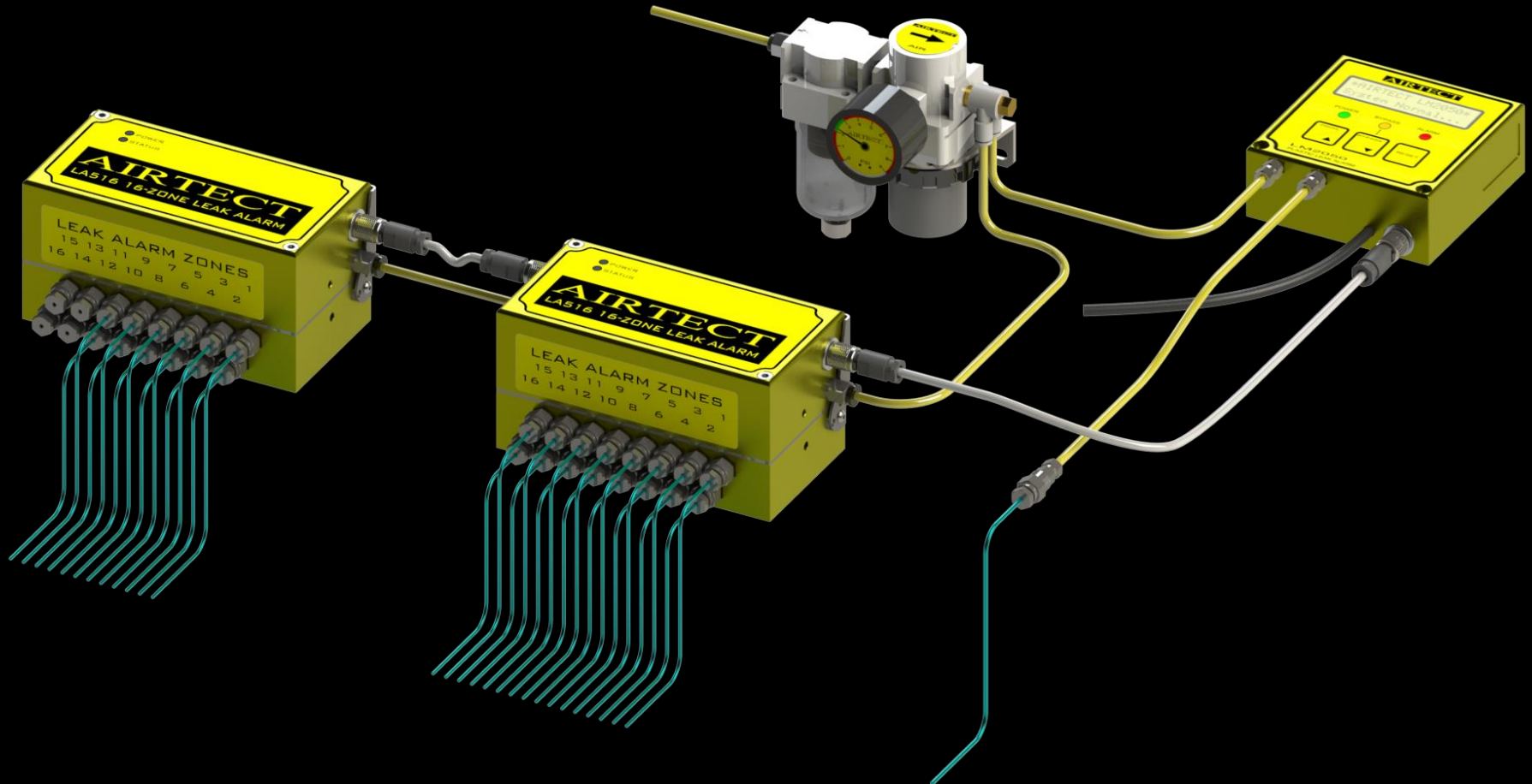

# AIRTECT

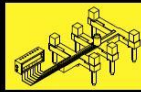

*Plastic Leak Alarm System*

**LM2050 PRACTICAL INSTALLATION**  
(single nozzle and multi-zone leak detection)



# AIRTECT

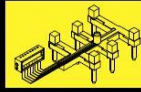

Plastic Leak Alarm System

**LA500 INSTALLATION**  
(single nozzle and 8-zone leak detection)

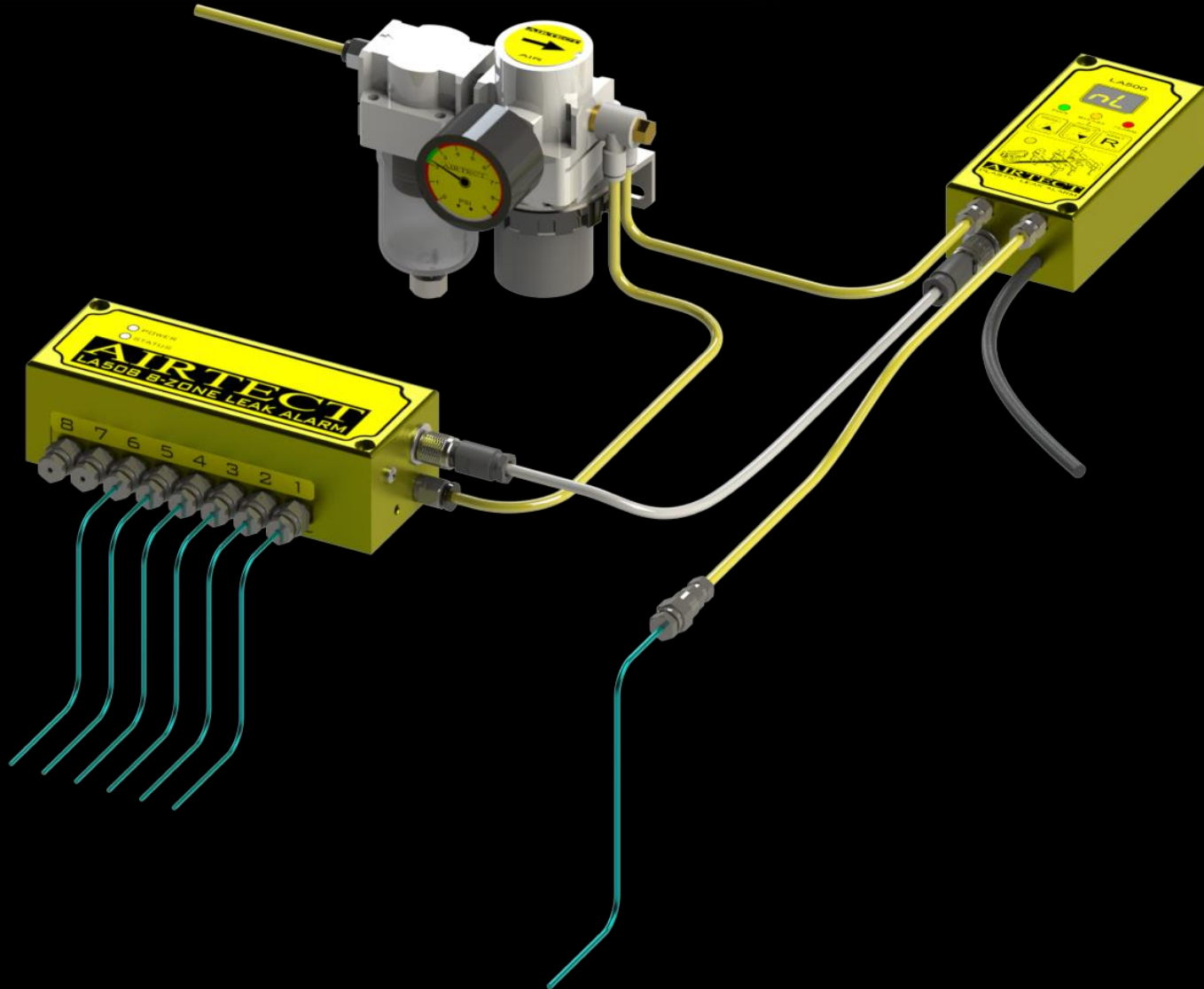



# AIRTECT

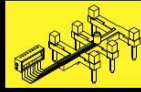

Plastic Leak Alarm System

## LA500 INSTALLATION

(single nozzle and 32-zone leak detection)

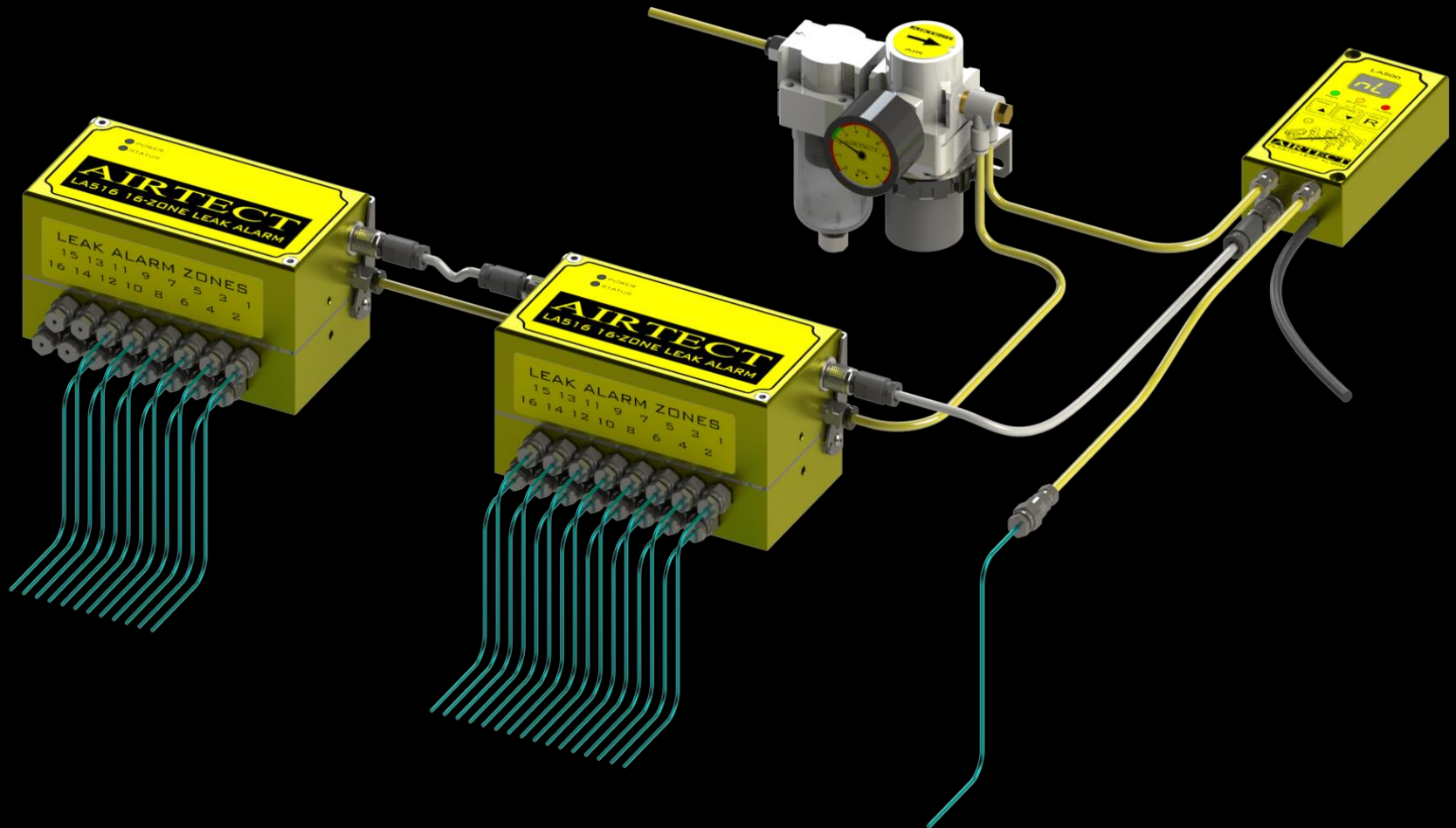

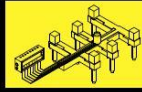





## INSTALLATION GUIDELINES:

1. The DC Power Source must be interference free. This means no Electromagnetic Interference (EMI) caused by solenoids and servomotors etc.
2. The internal interlock relay contacts have a capacity to switch loads of 24Vdc at a maximum current of 0.5A.
3. Ensure neat workmanship and run the wiring and plastic tubing within the machine enclosure where possible.
4. Ensure that both ends of all sensor tubes are cut neatly so as to provide a clear inner sensor tube diameter of 0.8mm (for 1.6mm tube) and 1mm (for 2mm tube).
5. When using expansion manifolds (LA504, LA508 etc) ensure the LA500 or LM2050 has been programmed to accept the manifold/s and that it/they are connected, otherwise a communication alarm will be displayed and vice-versa if the LA500 or LM2050 has not been programmed and a manifold is connected, a communication alarm will be displayed.
6. Electrical power should only be switched on AFTER the sensor tube installation is complete and the air supply is energised to allow the 'self teaching' function to work.
7. When using Modular systems, the manifolds must be mounted on the manifold base before applying electrical power as all mould leak sensor installations will be somewhat different.

### MANIFOLD LED INDICATIONS

-  POWER LED SHOULD BE CONTINUOUSLY LIT (NORMAL)
-  STATUS LED SHOULD FLASK EVERY 3-4 SECONDS (NORMAL)
-  STATUS LED WILL FLASH QUICKLY FOR COMMUNICATION 'DATA ERROR' WARNING
-  STATUS LED WILL FLASH RED / GREEN QUICKLY FOR 'INTERNAL SENSOR ERROR' WARNING

# AIRTECT

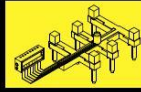

Plastic Leak Alarm System

## MANIFOLD INSTALLATION PHOTOS

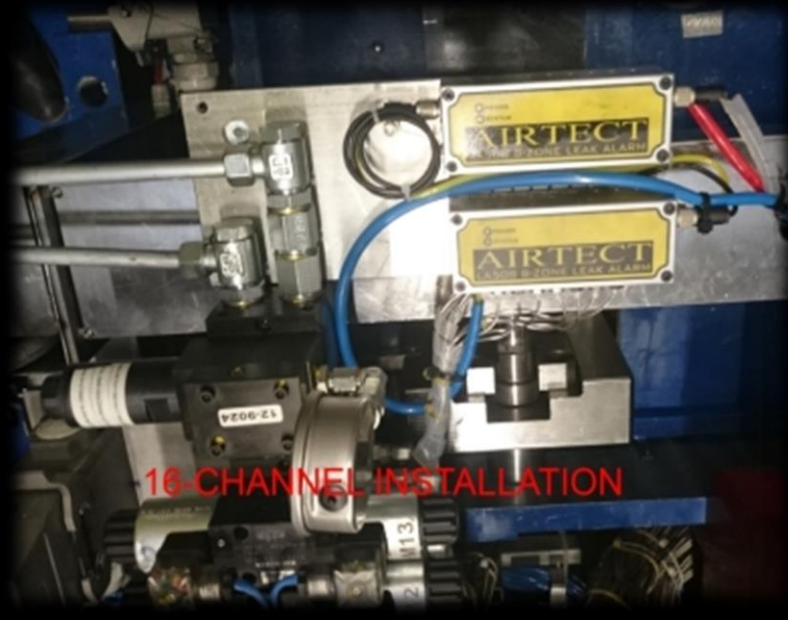

16-CHANNEL INSTALLATION

# AIRTECT

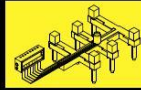

*Plastic Leak Alarm System*

## SENSOR TUBE INSTALLATION PHOTOS

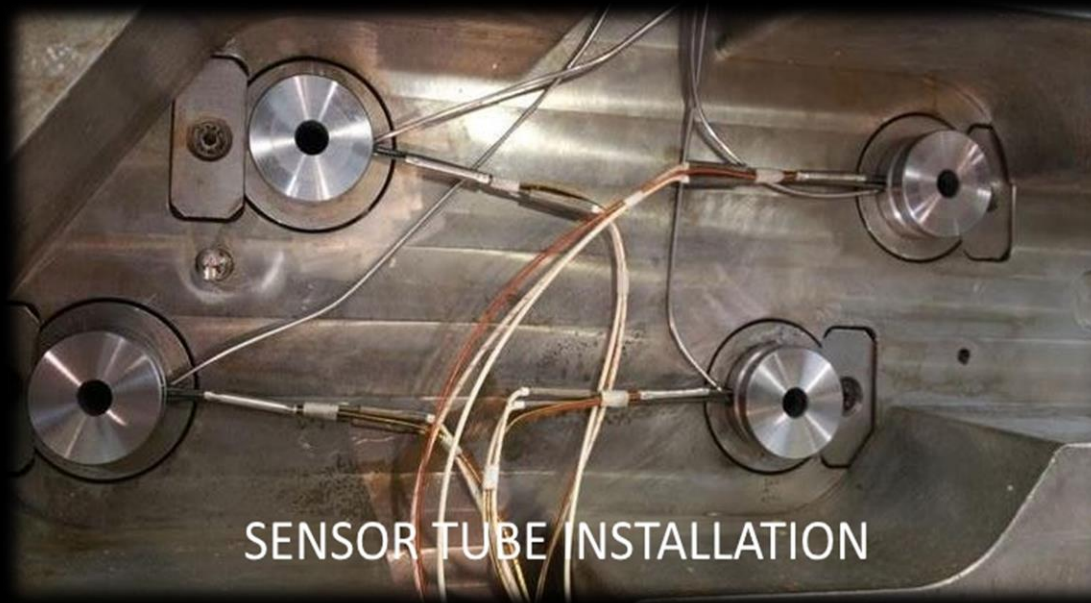
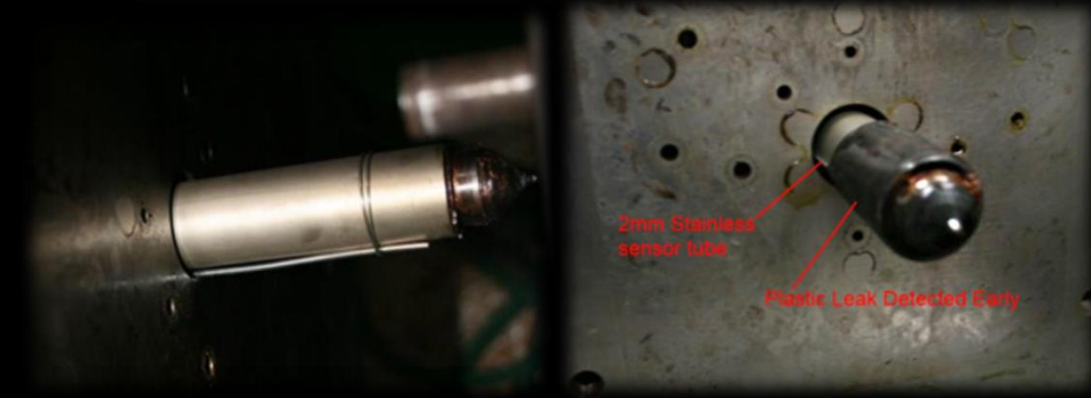

# AIRTECT

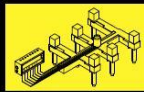

## SENSOR TUBE INSTALLATION PHOTOS

*Plastic Leak Alarm System*



# AIRTECT

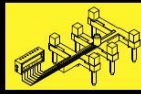

## SENSOR TUBE CUTTING RECOMMENDATIONS

*Plastic Leak Alarm System*

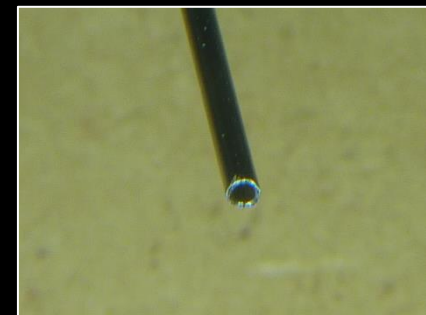
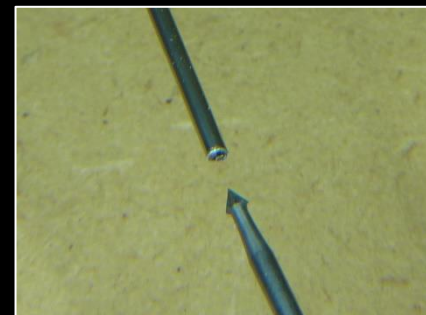
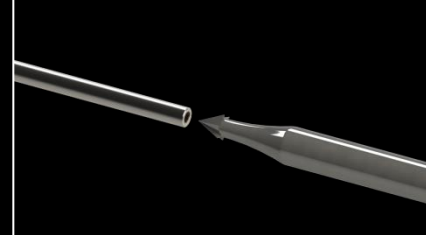
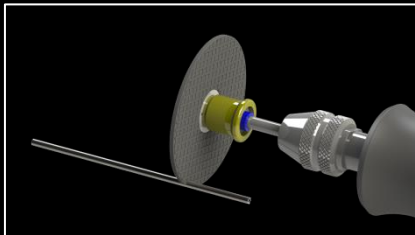
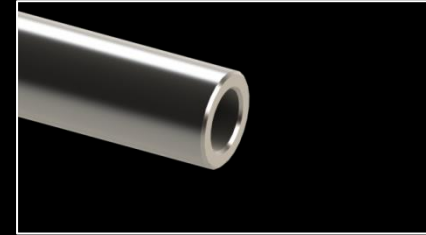
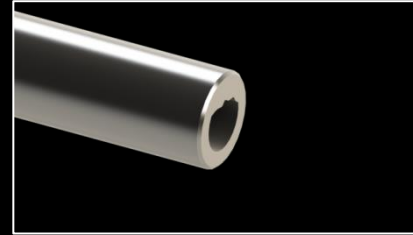
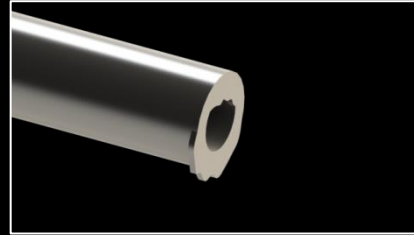

# AIRTECT

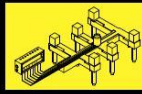

*Plastic Leak Alarm System*

**SENSOR TUBE INSTALLATION  
RECOMMENDATIONS**

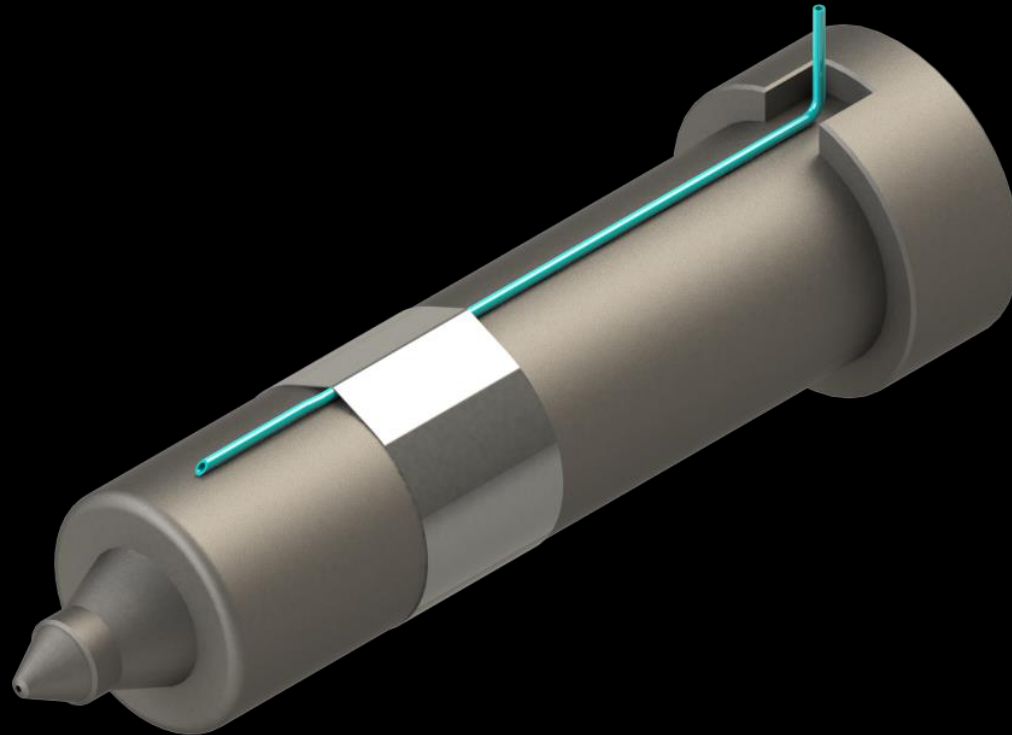

# AIRTECT

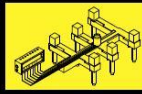

## SENSOR TUBE INSTALLATION RECOMMENDATIONS

*Plastic Leak Alarm System*

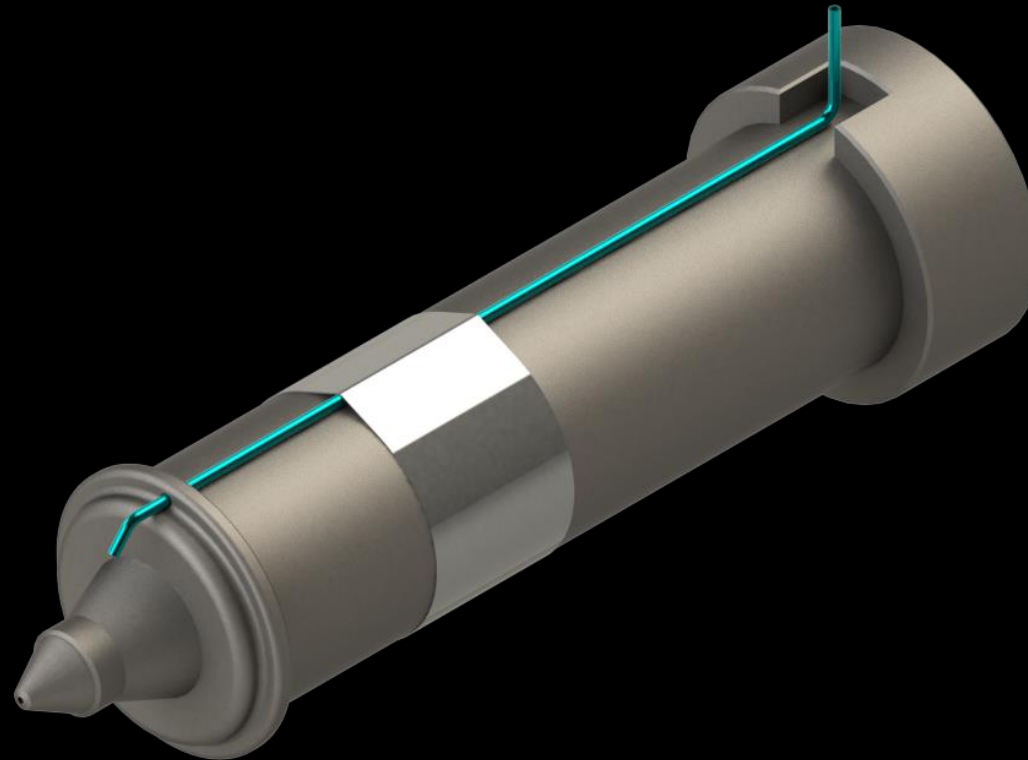



# AIRTECT

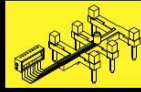

## SENSOR TUBE INSTALLATION RECOMMENDATIONS

*Plastic Leak Alarm System*

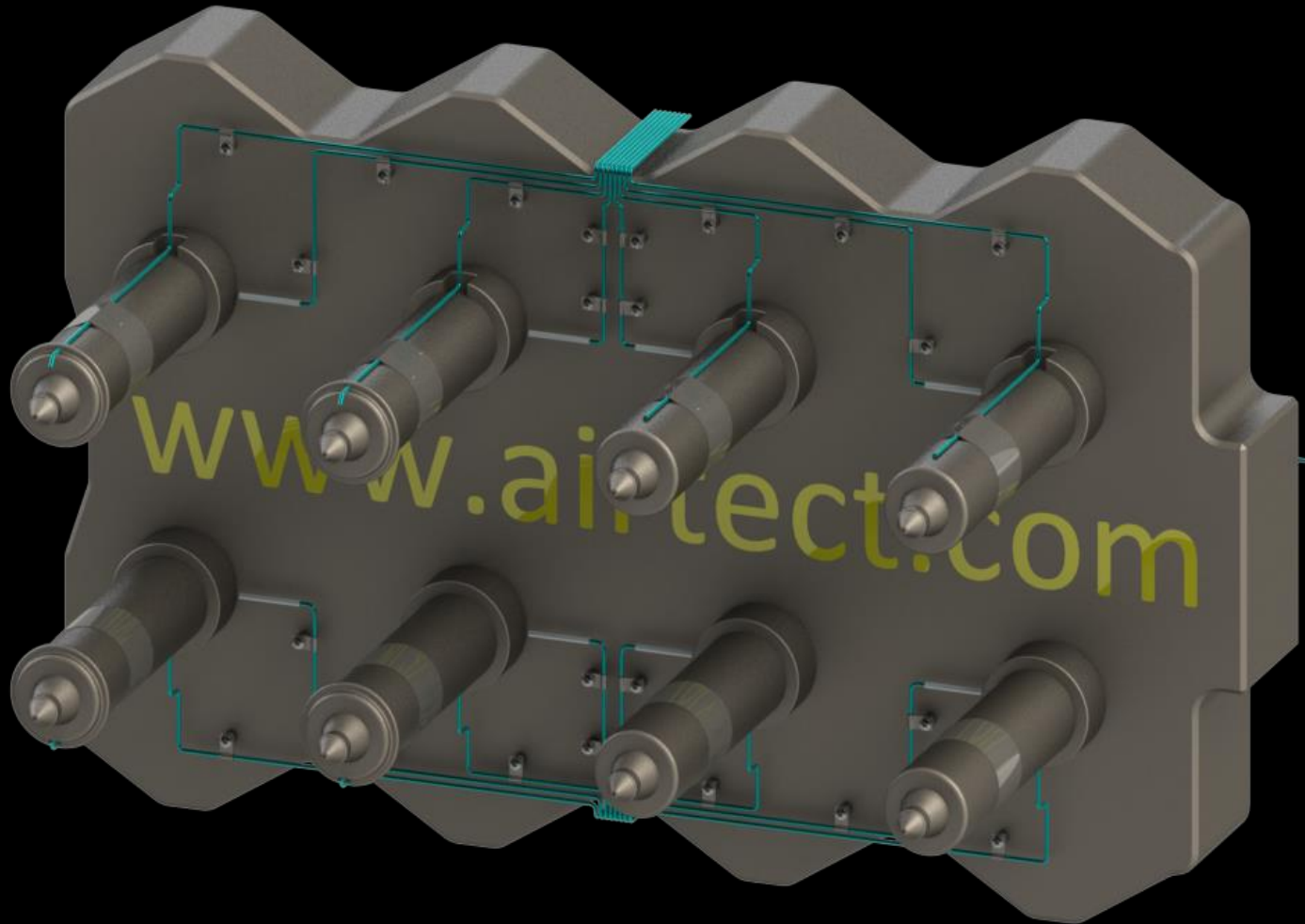

# AIRTECT

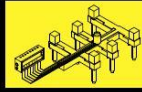

## SENSOR TUBE INSTALLATION RECOMMENDATIONS

*Plastic Leak Alarm System*

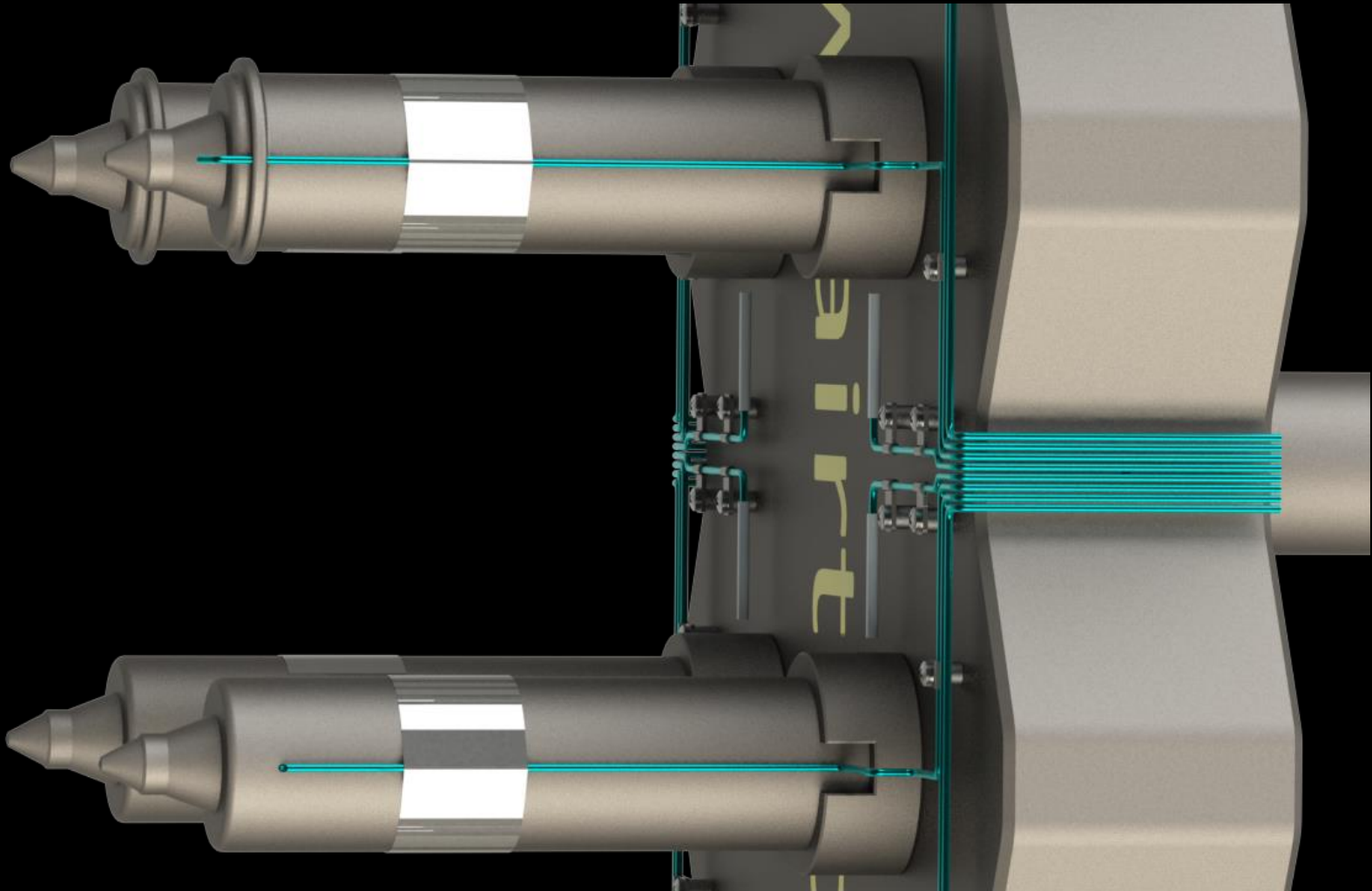

# AIRTECT

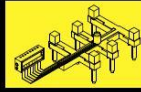

## SENSOR TUBE INSTALLATION RECOMMENDATIONS

*Plastic Leak Alarm System*

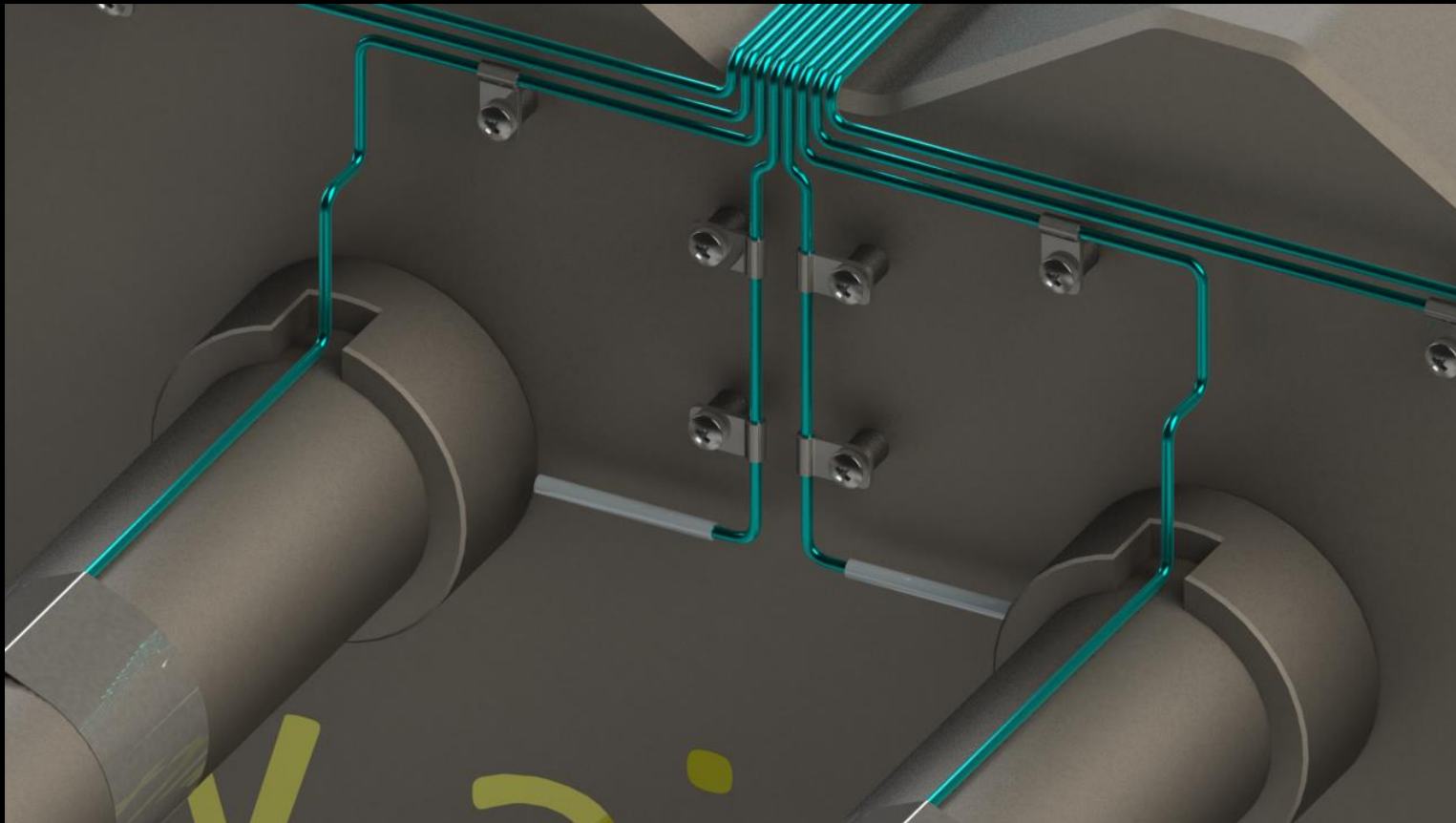

# AIRTECT

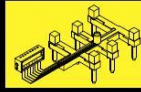

**SENSOR TUBE INSTALLATION  
RECOMMENDATIONS**

*Plastic Leak Alarm System*

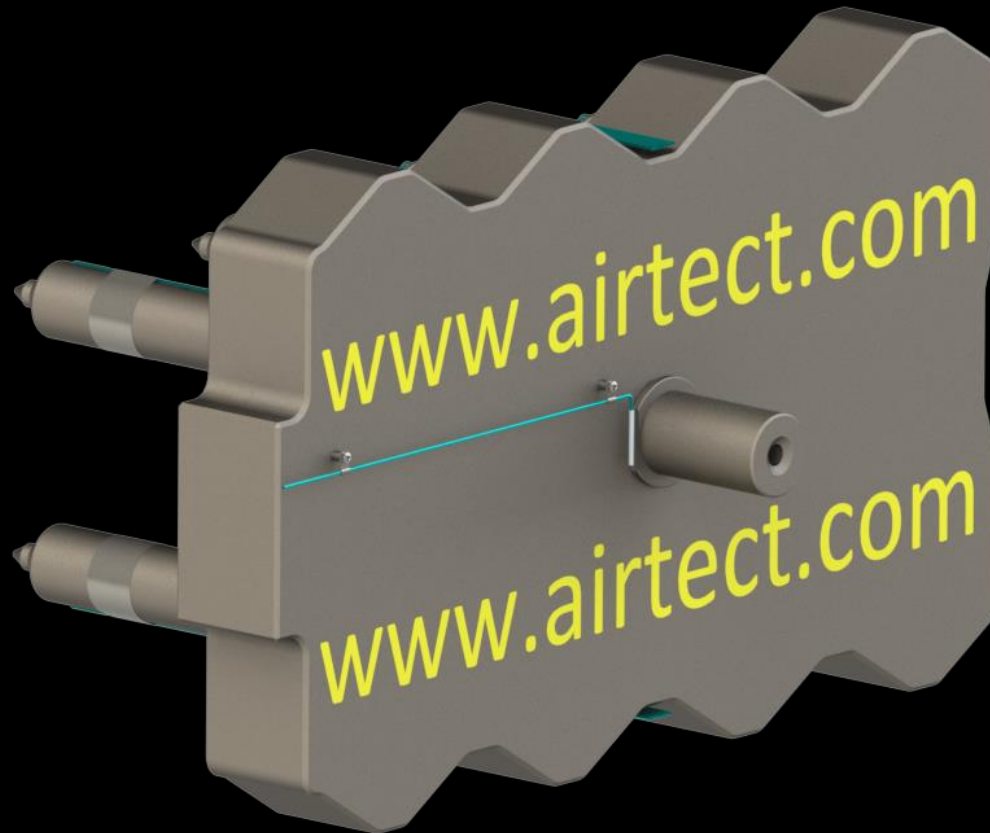

# AIRTECT

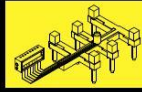

*Plastic Leak Alarm System*

**SENSOR TUBE INSTALLATION  
RECOMMENDATIONS  
'SERIES LINK'**



# AIRTECT

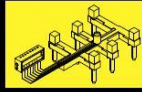

*Plastic Leak Alarm System*

**SENSOR TUBE INSTALLATION  
RECOMMENDATIONS  
'SERIES LINK'**

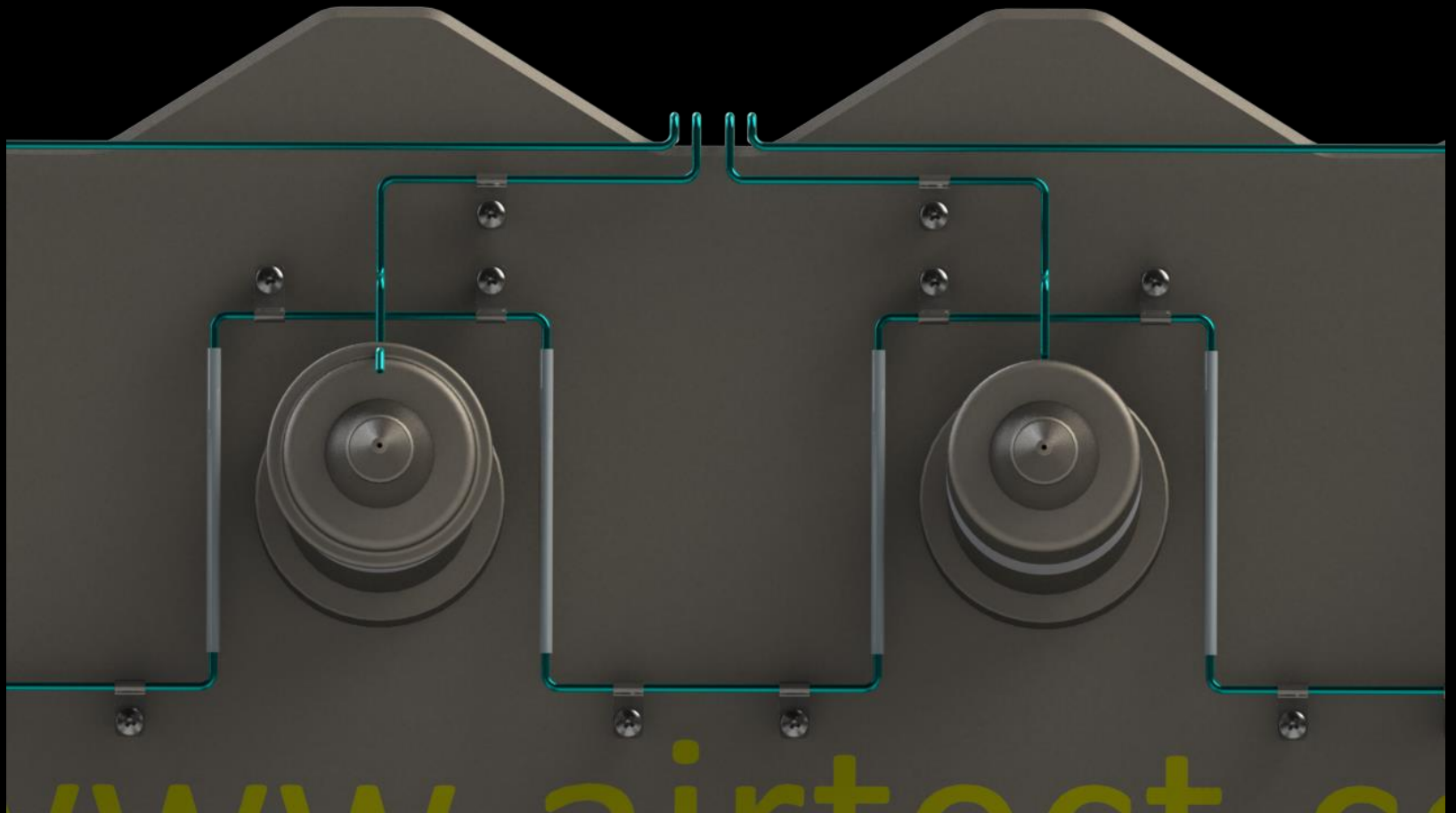

[www.airtect.co](http://www.airtect.co)

# AIRTECT

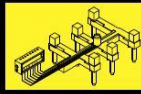

*Plastic Leak Alarm System*

**SENSOR TUBE INSTALLATION  
RECOMMENDATIONS  
'SERIES LINK'**

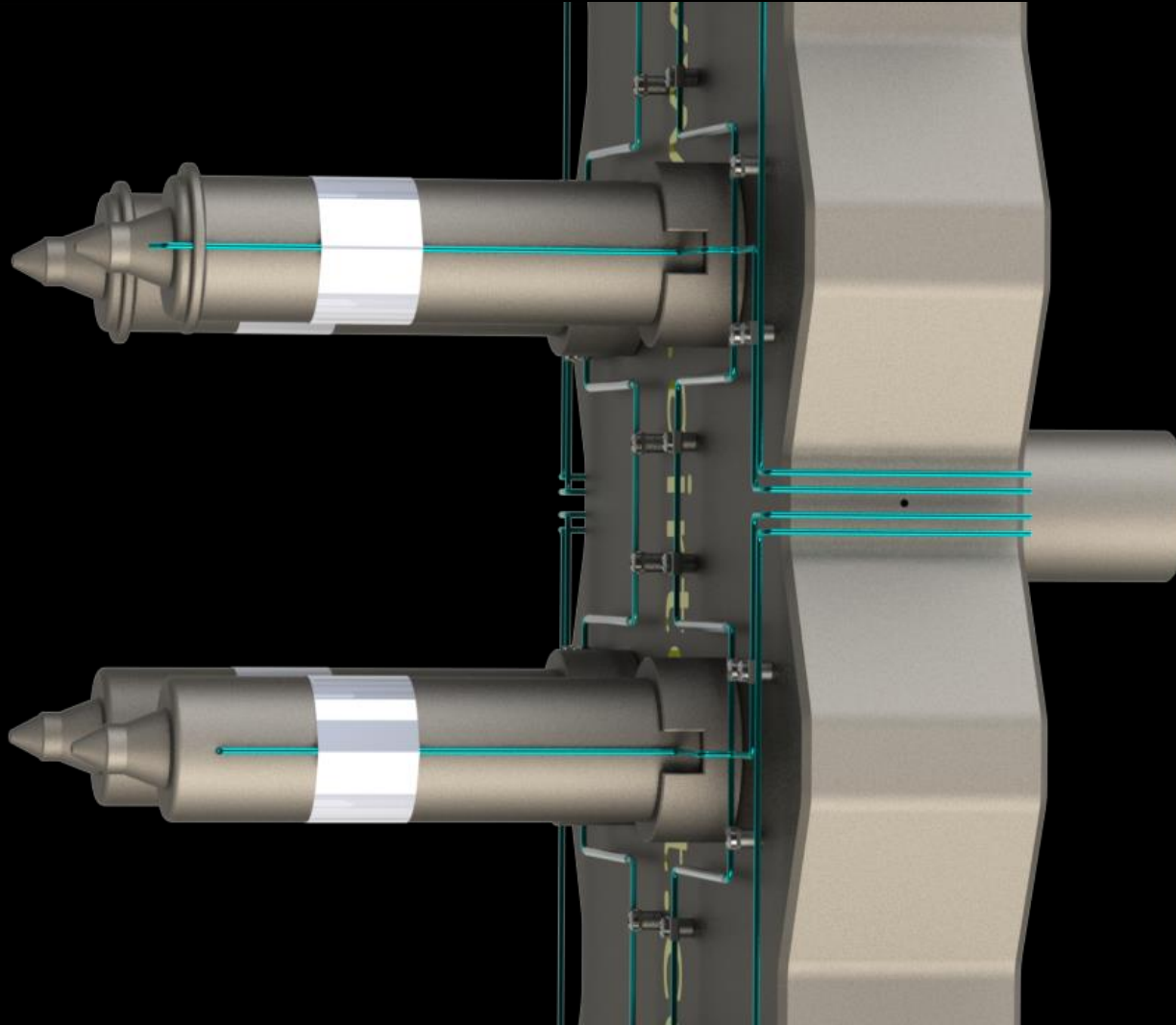

# AIRTECT

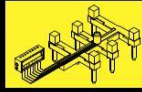

*Plastic Leak Alarm System*

**DETECT YOUR NOZZLE AND HOT  
RUNNER LEAKS EARLY!! ☺**

**MULTI-ZONE LEAK DETECTION SYSTEMS ARE AVAILABLE WITH OR  
WITHOUT PROGRAMMABLE CONTROL**

## **PROGRAMMABLE CONTROL ADVANTAGES (USING LA500 or LM2050)**

- **PROGRAMMABLE FUNCTIONS INCLUDE LEAK REPORTING AND INTERLOCK RELAY DELAY TIMERS, MANIFOLD TEMPERATURE ETC**
- **MULTIPLE MANIFOLD CONNECTION SYSTEMS (DAISY CHAIN).**
- **PROVIDE LEAK DETECTION AT MAIN INJECTION NOZZLE**

## **NON-PROGRAMMABLE CONTROL ADVANTAGES (STAND-ALONE MANIFOLDS)**

- **LOW COST ALTERNATIVE**
- **LEAK LOCATION DISPLAYED ON MANIFOLD**
- **FIXED 10 SECOND INTERLOCK RELAY DELAY TIMER**
- **AVAILABLE IN FIXED OR MODULAR UNITS, SAME AS ABOVE.**
- **AUTO-RESET OF ALARMS**
- **SAME ELECTRICAL CONNECTIONS AS LA500/LM2050**
- **NO PCC CABLES**

**NOTE: THESE UNITS CANNOT BE EXPANDED (DAISY CHAINED)**



# AIRTECT

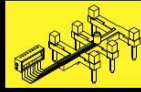

**DETECT YOUR NOZZLE AND HOT  
RUNNER LEAKS EARLY!! ☺**

*Plastic Leak Alarm System*

## LA504S 4-ZONE 'STAND-ALONE' EXAMPLE

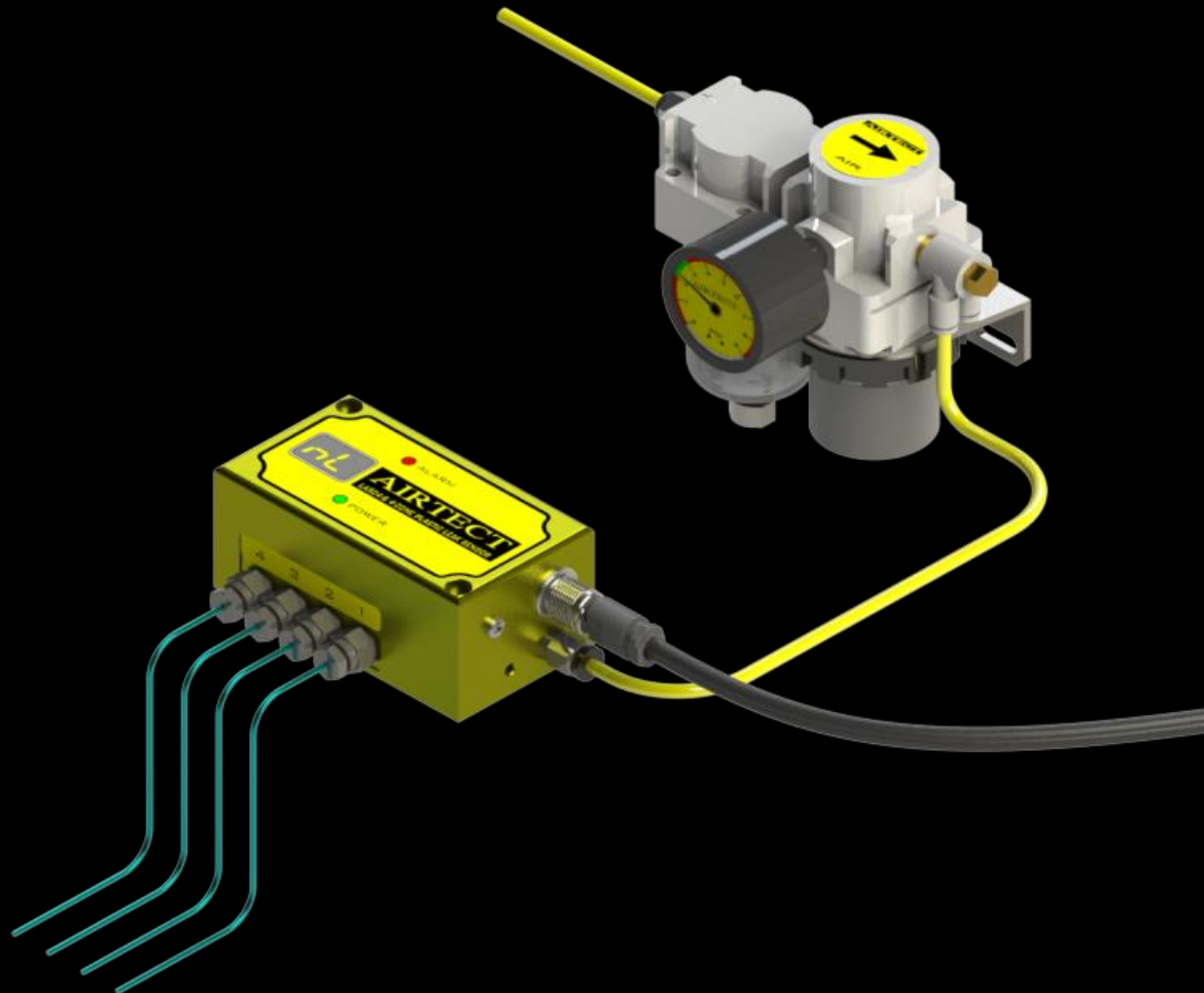

# AIRTECT

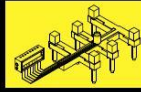

*Plastic Leak Alarm System*

**DETECT YOUR NOZZLE AND HOT  
RUNNER LEAKS EARLY!! ☺**

**LA508S 8-ZONE 'STAND-ALONE' EXAMPLE**

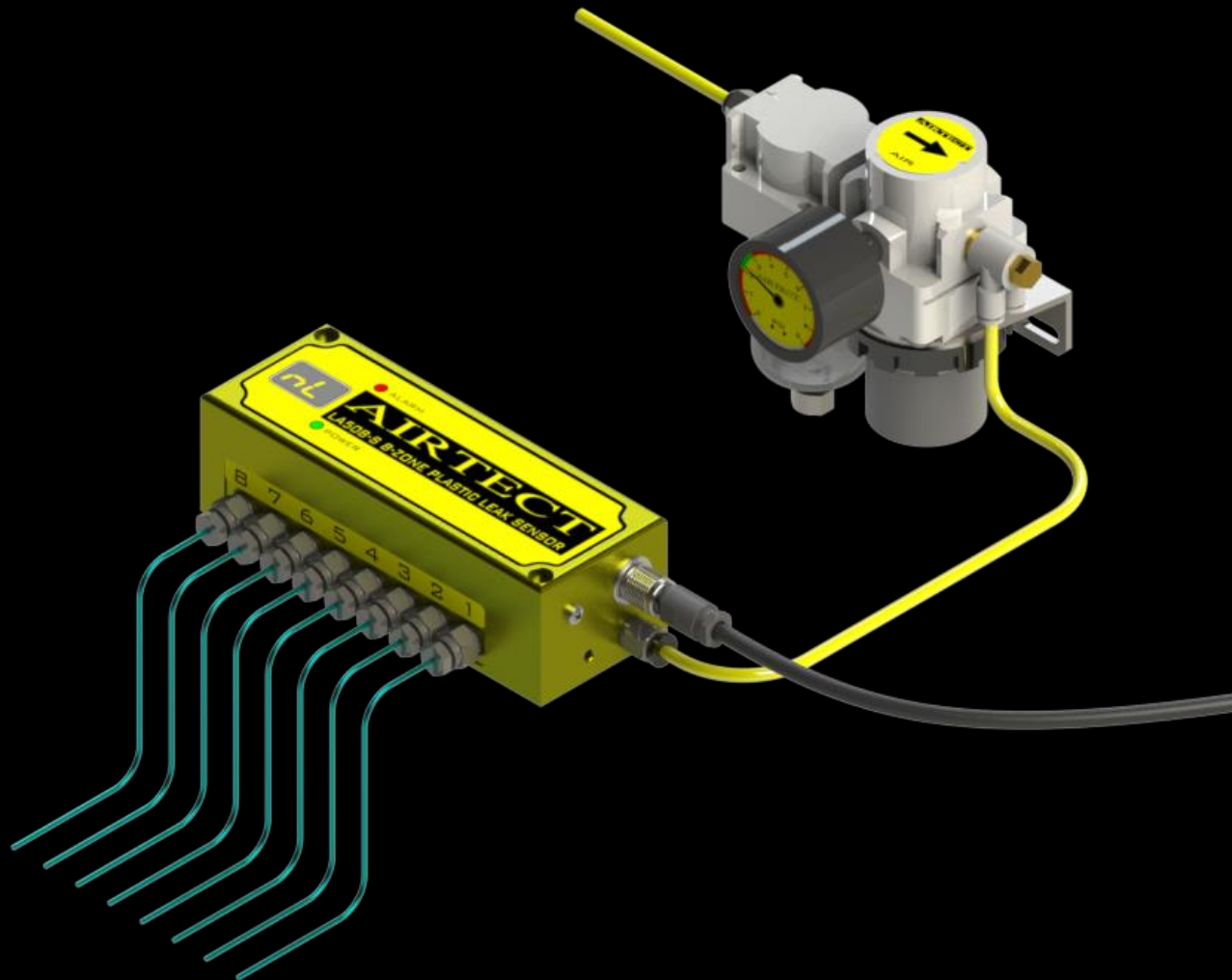

# AIRTECT

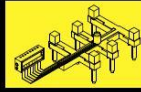

**DETECT YOUR NOZZLE AND HOT  
RUNNER LEAKS EARLY!! ©**

*Plastic Leak Alarm System*

**LA516S-M-S 16-ZONE 'STAND-ALONE' EXAMPLE**

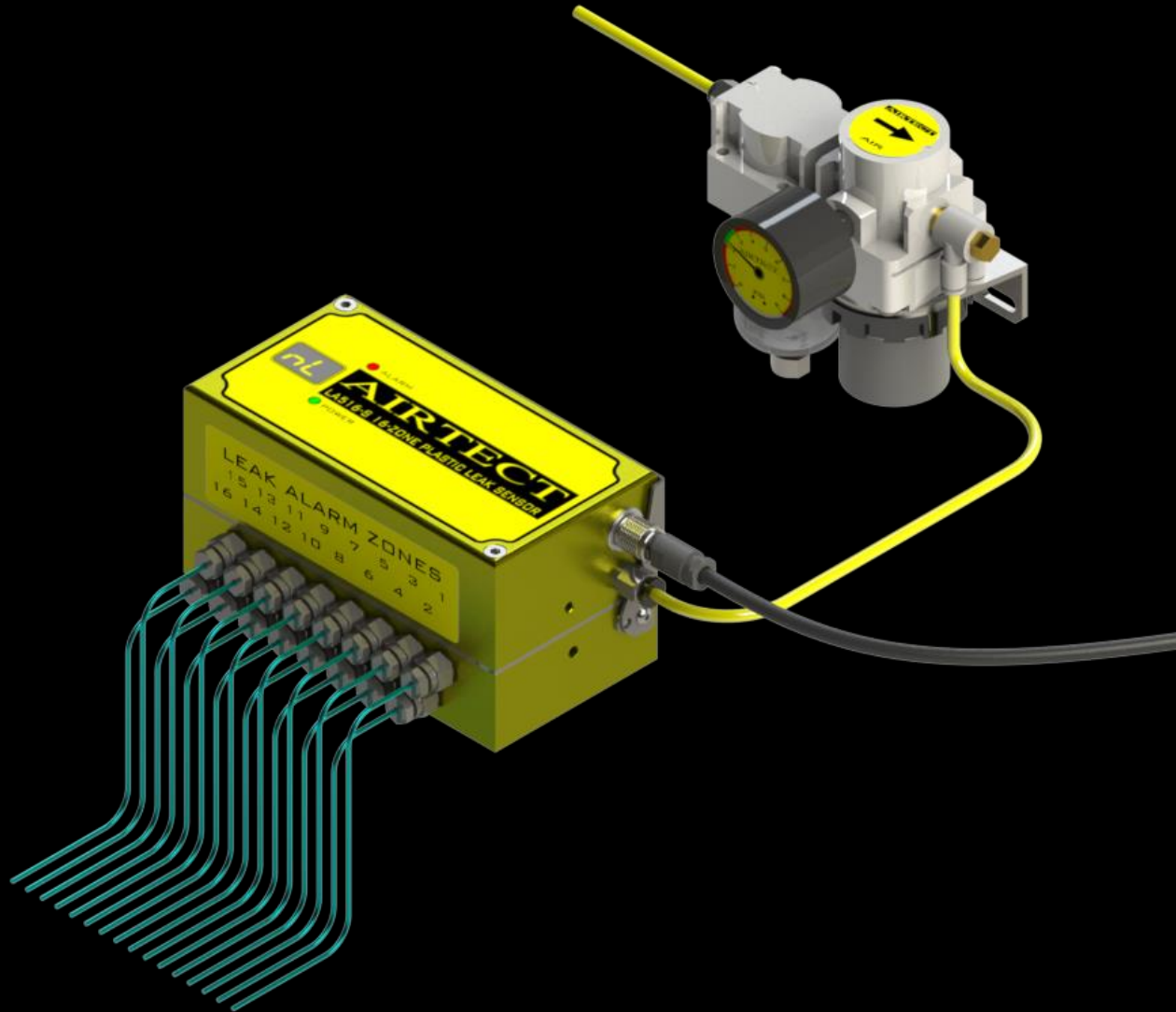

# AIRTECT

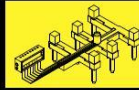

Plastic Leak Alarm System

**LA504S/LA508S/LA516S**  
**ELECTRICAL INSTALLATION**  
 (stand alone manifolds)

## PNP SYSTEM

Ex : LA504S

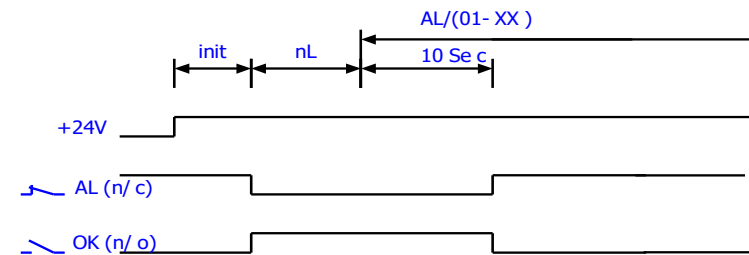
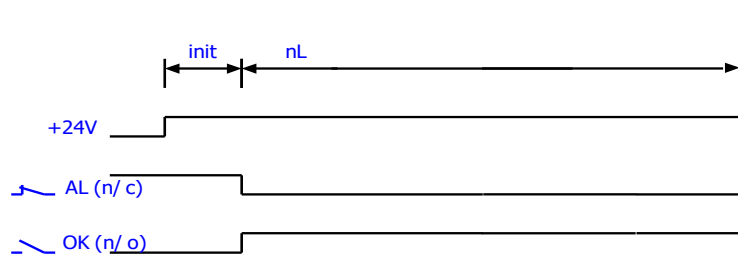
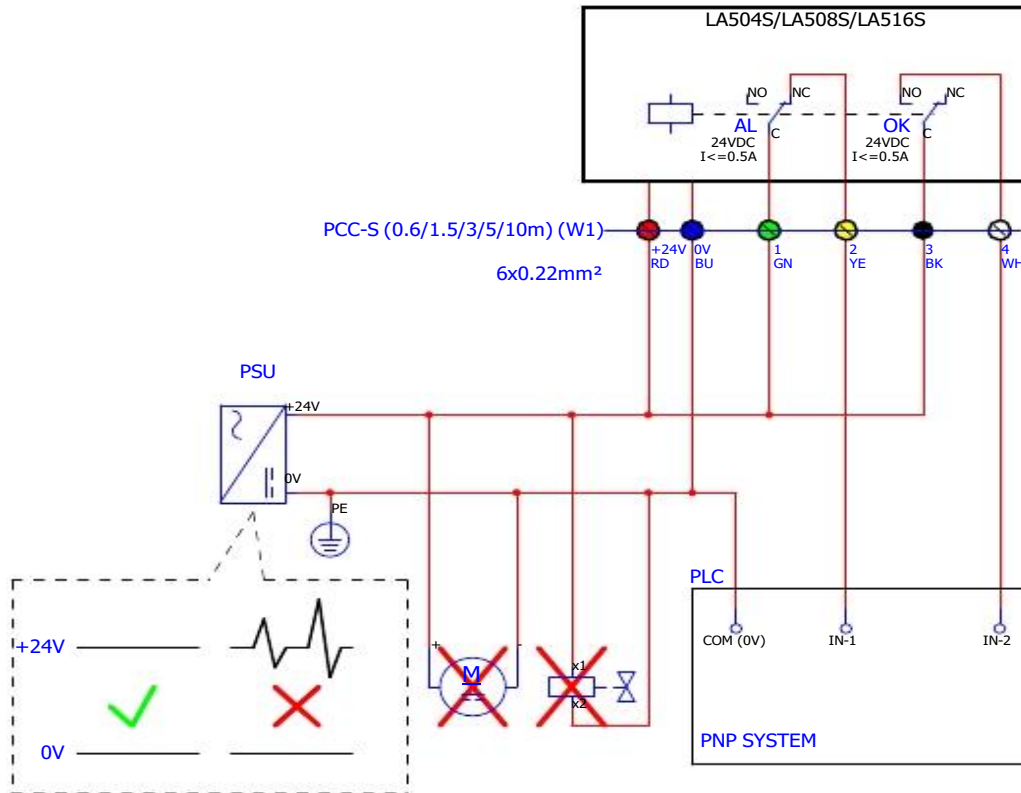
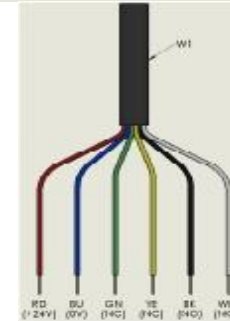

# AIRTECT

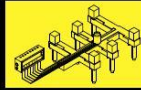

Plastic Leak Alarm System

## LA504S/LA508S/LA516S ELECTRICAL INSTALLATION (stand alone manifolds)

### NPN SYSTEM

Ex : LA504S

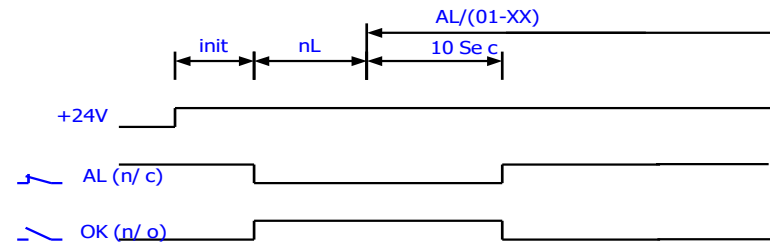
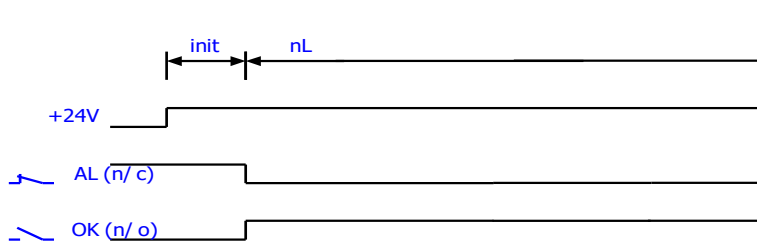
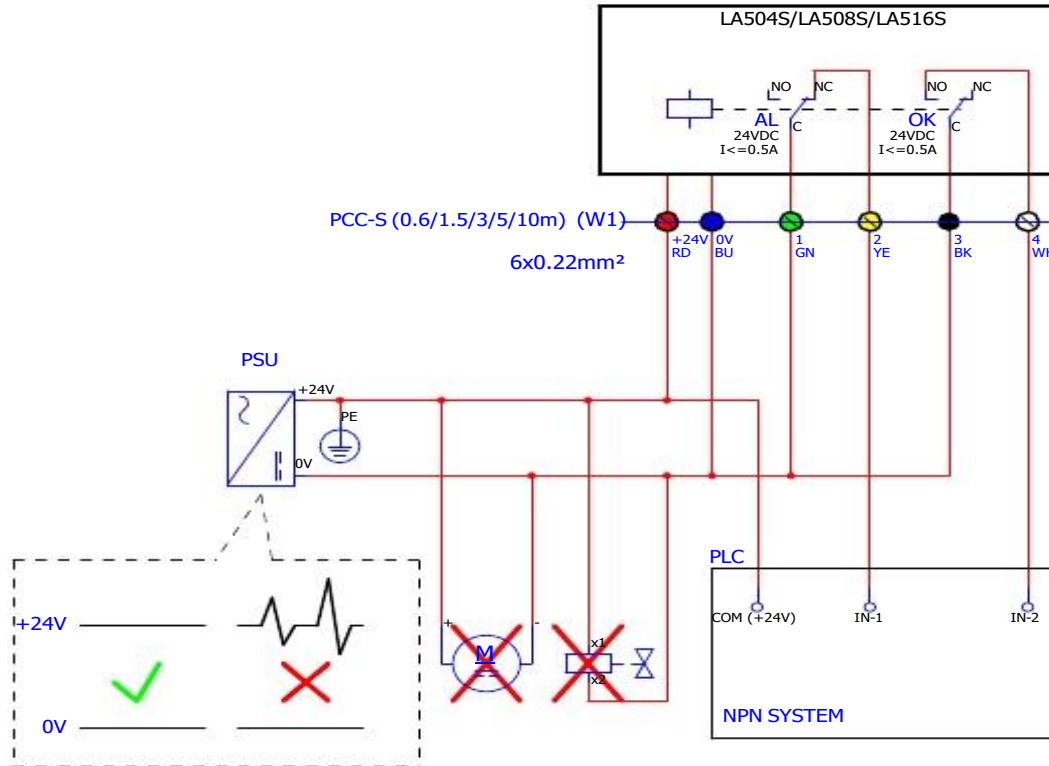
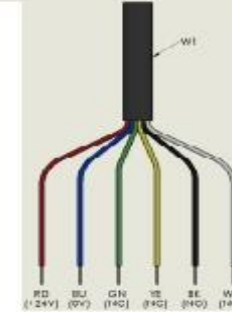

!!!

# AIRTECT

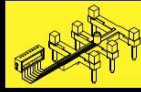

DETECT YOUR NOZZLE AND HOT  
RUNNER LEAKS EARLY!! ©

Plastic Leak Alarm System

## 4-ZONE LEAK DETECTION SYSTEM OPTIONS WITH PROGRAMMABLE CONTROL

LA500



or

LM2050



+

LA504



+ PCC-X

FIXED 4-ZONE

LA500



or

LM2050



+

LA504-M-H



+ PCC-X

LA504-B

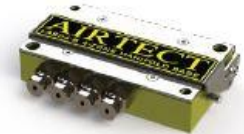

MODULAR 4-ZONE

LA500



or

LM2050



+

LA504-M-S



+ PCC-X

LA504-B



MODULAR 4-ZONE

# AIRTECT

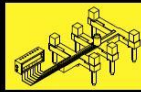

DETECT YOUR NOZZLE AND HOT  
RUNNER LEAKS EARLY!! ☺

*Plastic Leak Alarm System*

## 4-ZONE LEAK DETECTION SYSTEM OPTIONS WITHOUT PROGRAMMABLE CONTROL

LA504-S



FIXED STAND-ALONE 4-ZONE

LA504-S-M-H



+

LA504-B



MODULAR STAND-ALONE 4-ZONE

LA504-S-M-S



+

LA504-B



MODULAR STAND-ALONE 4-ZONE

# AIRTECT

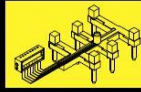

DETECT YOUR NOZZLE AND HOT  
RUNNER LEAKS EARLY!! ©

Plastic Leak Alarm System

## 8-ZONE LEAK DETECTION SYSTEM OPTIONS WITH PROGRAMMABLE CONTROL

LA500



or

LM2050



+

+ PCC-X

LA508-N



FIXED 8-ZONE

LA500

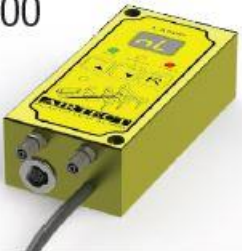

or

LM2050



+

+ PCC-X

LA508-M-H-N



+

MODULAR 8-ZONE

LA508-B



LA500



or

LM2050



+

+ PCC-X

LA508-M-S-N



+

MODULAR 8-ZONE

LA508-B





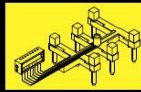

## 8-ZONE LEAK DETECTION SYSTEM OPTIONS WITHOUT PROGRAMMABLE CONTROL

LA508-S



FIXED STAND-ALONE 8-ZONE

LA508-S-M-H



+

LA508-B



MODULAR STAND-ALONE 8-ZONE

LA504-S-M-S



+

LA508-B



MODULAR STAND-ALONE 8-ZONE

# AIRTECT

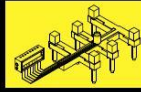

Plastic Leak Alarm System

DETECT YOUR NOZZLE AND HOT  
RUNNER LEAKS EARLY!! ☺

## 16-ZONE LEAK DETECTION SYSTEM OPTIONS WITH PROGRAMMABLE CONTROL

LA500



or

LM2050



+

+ PCC-X

LA516-M-H-N



+

MODULAR 16-ZONE

LA516-B



LA500



or

LM2050



+

+ PCC-X

LA516-M-S-N



+

MODULAR 16-ZONE

LA516-B



# AIRTECT

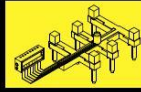

DETECT YOUR NOZZLE AND HOT  
RUNNER LEAKS EARLY!! ☺

*Plastic Leak Alarm System*

## 16-ZONE LEAK DETECTION SYSTEM OPTIONS WITHOUT PROGRAMMABLE CONTROL

LA516-S-M-H



+

LA516-B



MODULAR STAND-ALONE 16-ZONE

LA504-S-M-S



+

LA516-B



MODULAR STAND-ALONE 16-ZONE

# AIRTECT

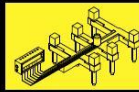

**DETECT YOUR NOZZLE AND HOT  
RUNNER LEAKS EARLY!! ☺**

*Plastic Leak Alarm System*

## ACCESSORIES

AR-20GF



Air pressure regulator + gauge,  
air filter and fittings

PU TUBE

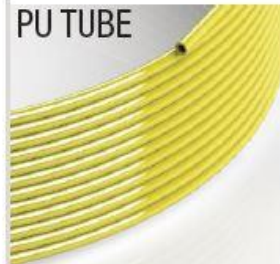

Plastic tubing

PCC



Power/communication cable

TUBE-SIL



Silicone rubber tubing

LA-MAN-4

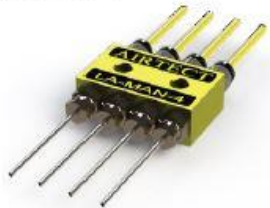

Tube adaptor

LA-MAN-2



Tube adaptor

NUT-SS



Nut and olive set

FIT-PU-SS



Fitting for tubing

FIT-SS-SS



Fitting for stainless tubing

TUBE-SS



Stainless steel tubing

BKT-SS



Fixing bracket

PCC-S



Power / Interlock cable

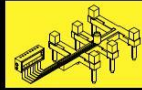

## **FREQUENTLY ASKED QUESTIONS**

- **Q: How much compressed air is used?**  
**A: 0.05 Litres per minute per sensor of compressed air at 2PSI.**
- **Q: What is the difference between the LA500 and LM2050.**  
**A: There is no functional difference. Only the Clear Text LCD display with multiple language options.**
- **Q: How much DC power is required?**  
**A: 24Vdc @ 150mA average for LM2050 + LA508. Please note the DC power Source must be free from Electromagnetic Interference (EMI), caused by many devices such a solenoid valves, servo motors etc working on the sale DC power line. Good electrical practice will eliminate all potential problems.**
- **Q: How long can the stainless steel sensor tubes be?**  
**A: The design is for a maximum of about 5 meters.**
- **Q: What is the minimum bend radius for the stainless steel tubes without affecting air flow?**  
**A: R1.6mm for the 1.6mm diameter tube and R2 for the 2mm diameter tube.**
- **Q: Where is the Silicone Rubber tube used?**  
**A: At the end of the stainless steel sensor tube at the main injection nozzle. It is also used within a Hot Runner mould where the temperature is less than 270°C.**

# AIRTECT

*Plastic Leak Alarm System*

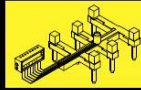

**DETECT YOUR NOZZLE AND HOT  
RUNNER LEAKS EARLY!! ☺**

**FOR FURTHER INFORMATION  
CONTACT:**



**De Scheper 319 /1 - 5688HP Oirschot**

Tel. +31 499 550520

4moulding.nl - mouldshop.nl